



Installation Guide



Table of Contents

Index of Tables	2
Index of Figures.....	2
Introduction.....	3
Chamber Handling and Storage.....	3
Foundation and Bedding Preparation	4
Inlet Manifold Assembly and Chamber Placement.....	6
Chamber Outlet Options	10
Pre-treatment / Sediment Row	11
Stormwater Quality Unit Option.....	11
Sediment Row Option	11
Vent / Inspection Port Placement	13
Chamber Backfill Requirements	14
Minimum and Maximum Cover Heights.....	16

Index of Tables

Table 1 - Suitable Geotextiles	5
Table 2 – Acceptable Backfill Materials	14
Table 3 - Backfill Placement & Compaction Recommendations	16
Table 4 - Maximum Allowable Construction Vehicle Loads	17

Index of Figures

Figure 1 - Chambers on a Truck.....	3
Figure 2 – Minimum 72” Forks for Unloading Chamber Pallets	2
Figure 3 - Chamber Handles.....	2
Figure 4 - Chamber Unloading from Pallets.....	3
Figure 5 – Excavation Footprint for Chambers.....	4
Figure 6 - Filter Fabric Installation	5
Figure 7- Bedding Compaction with Plate Compactor.....	6
Figure 8 - Optional Perimeter Drain.....	6
Figure 9 - Inlet Manifold Options	7
Figure 10 - Inlet Scour Protection.....	7
Figure 11 - Manifold / End Cap Connection	8
Figure 12 - End Cap Assembly.....	8
Figure 13 - Chamber Joint Assembly	9
Figure 14 - Minimum Chamber Row Spacing	9
Figure 15 - Outlet Manifold Configuration	10
Figure 16 - Prinsco Stormwater Quality Unit (SWQU).....	11
Figure 17 - Sediment Row	12
Figure 18 - Inspection Ports	13
Figure 19 - Chamber Cross Section	14
Figure 20 - Backfill Placement with Excavator	15
Figure 21 - Embedment Stone Placement.....	15
Figure 22 - Perimeter Backfill Placement.....	15
Figure 23 - Filter Fabric over Top of Chambers	16

Introduction

HydroStor stormwater chambers are designed to provide a highly efficient solution for underground water management. HydroStor Chambers are high performance arch shaped chambers designed to rigorous ASTM F2418 and ASTM F2787 requirements. However, as with any buried structure, it is important to follow the guidelines contained herein to ensure structural integrity and maximum service life. In addition, the chamber supplier, chamber installer (site contractor) and the design engineer are encouraged to meet for a pre-construction meeting to discuss any questions relating to the installation process, and the guidelines herein. Below is a checklist of Materials/Equipment that will be typically be needed for each HydroStor chamber system.

- HydroStor Chambers & End caps
- Woven & Non-woven Geotextiles
- Manifold pipe, fittings & couplers
- Acceptable backfill material found in Table 2
- Pre-treatment System
- Inlet Diversion Structure for sediment row (optional)
- PVC pipe & fittings for inspection port (optional)
- Minimum 72" forks for unloading chamber pallets
- Reciprocating saw for coring holes in end caps
- Approved compaction equipment
- Excavator to dig trench and place stone and soil backfill
- Stone conveyor / lightweight tracked dozer not exceeding 1,100 lbs/sf to grade backfill

Chamber Handling and Storage

Upon delivery to the project site, visually inspect the chambers and end caps to ensure accurate quantities. Any damage that may have occurred during transport should also be noted at this time. Chambers will be marked with either an identification sticker or tag listing the product name, nominal size and the governing standards.

The HS180 chambers will be delivered with up to 17 stacked chambers per pallet and the HS75 chambers with up to 32 stacked chambers on a pallet. Unloading of the chambers pallets should be done with a forklift with a minimum of 72" forks. Chambers and end caps may remain on the pallets until they are ready to be installed.



Figure 1 - Chambers on a Truck

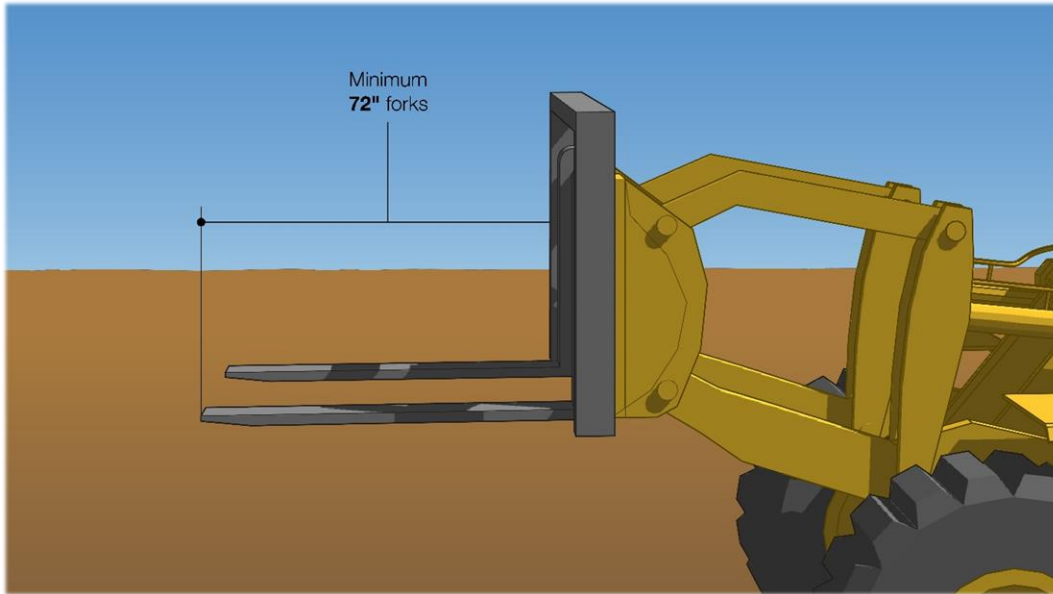

Figure 2 – Minimum 72" Forks for Unloading Chamber Pallets

Chambers should be stored in an area that is flat and free of debris. To avoid the potential for damage, the storage area should be located far enough away from construction traffic to avoid potential contact.

HydroStor chambers were designed with the installer in mind and are equipped with handles to allow the chambers to be moved and set in place with ease.

To remove chambers from the pallets, carefully cut and remove the banding from around the chambers. With two people, use the handles to lift the chambers off of the pallet and carry them into place.

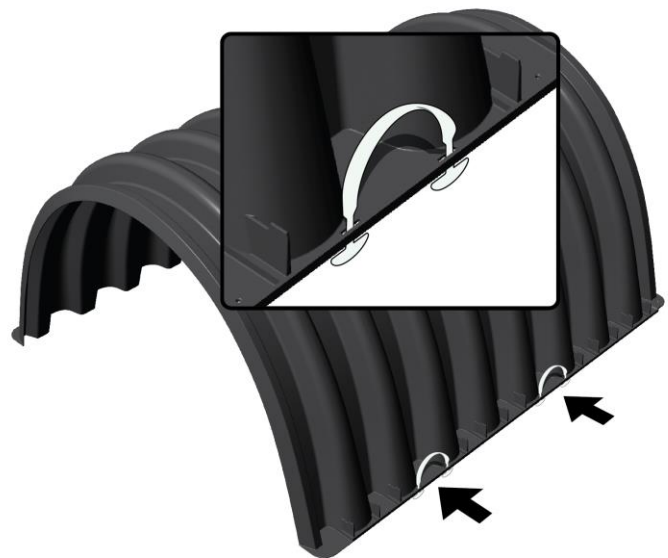

Figure 3 - Chamber Handles

WARNING: THE CHAMBERS MUST NOT BE REMOVED FROM THE STACK BY PUSHING THEM OFF FROM ONE SIDE. REMOVING THE CHAMBERS IN THIS MANNER MAY RESULT IN CHAMBER DAMAGE, INJURIES OR EVEN DEATH.



Figure 4 - Chamber Unloading from Pallets

Foundation and Bedding Preparation

Due to the inherent hazards associated with excavation, special precautions should be taken. All Federal Occupational Safety and Health Administration (OSHA), State and Local safety requirements should be followed.

Using the project plans and the appropriate details, excavate the chamber system bed in a manner to sufficiently accommodate the chambers and manifolds. To ensure an adequate fit, and to allow for a stone border, a minimum of 12" of excavation is required between the trench sidewalls and the chamber system.

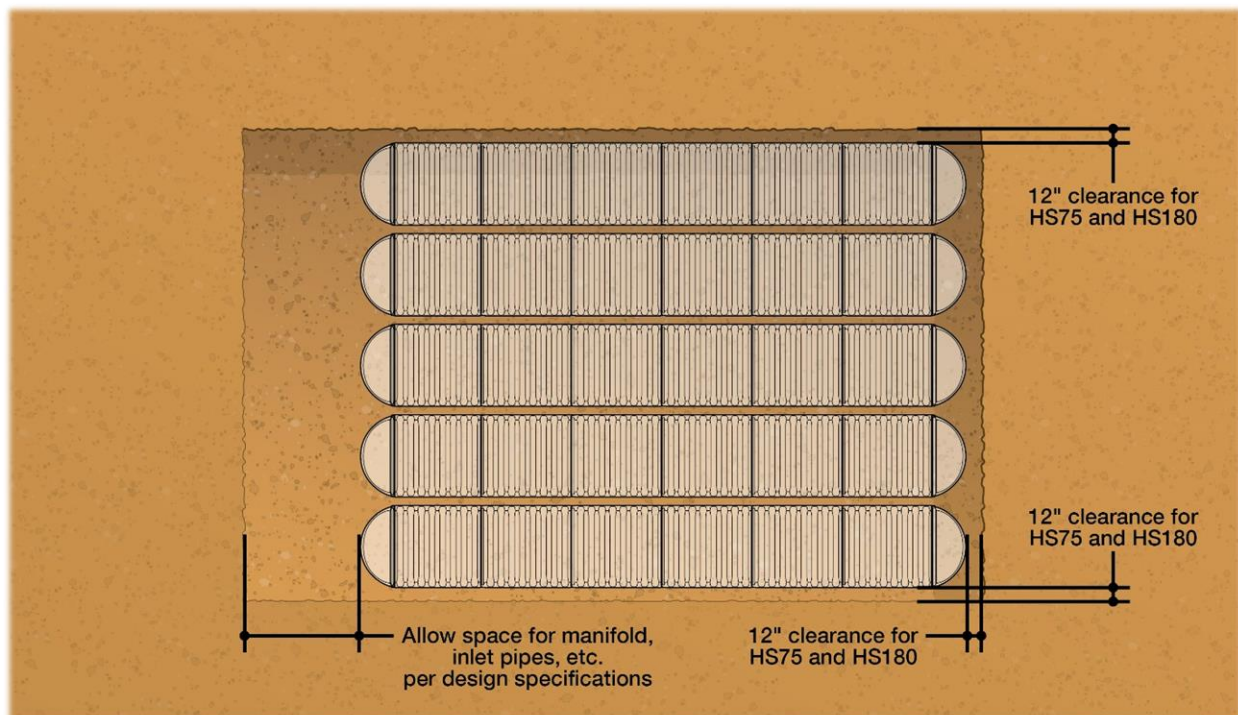

Figure 5 – Excavation Footprint for Chambers

Water within the excavation area should be controlled before and during the chamber installation. If standing water is present, dewatering measures should be utilized. There are many dewatering methods including but not limited to: sump pumps, well points, deep wells, underdrains, and stone blankets. The method of dewatering, if required, shall be selected based on the site conditions and severity of the water.

The HydroStor chambers depend on a stable foundation for support, an unstable foundation can result in differential settlement or other structural distress. If an unstable foundation is encountered, it shall be remedied prior to chamber bedding placement. There are several methods of improving the foundation prior to installation depending on the soil conditions present. Consult the design engineer for the desired method based on the site conditions.

- **Reinforce** – Soft soils are reinforced by adding dry soil, stabilizing geotextile or geogrid materials, or lime and then compacting for stabilization.

- Displace – Soupy soils are displaced by placing an overburden material such as large aggregate in the bottom until the foundation is consolidated and stabilized.
- Restore – Loose soils can be restored by compacting to a greater density.
- Remove – Existing soils that are unusable should be completely excavated and replaced with a suitable material.

Upon the prepared foundation, place an AASHTO M288 Class 2 non-woven filter fabric (4 or 6 oz is recommended) for the separation layer on the bed bottom and up and along the sidewalls. Refer to Table 1 for suitable geotextile options. Other geotextile options may be acceptable and should be approved by the design engineer. Maintain a 24” overlap of fabric at all seams. Fabric will also be required over top of the system after the embedment stone is placed over the chambers (minimum 12” for HS180 and 6” for HS75 chambers).

Geotextile Specification	AASHTO M288 Class 2 Non-woven Separation & Filtration	AASHTO M288 Class 1 Woven Stabilization & Scour Protection
Geotextile Placement	Separation Layer between angular stone and in-situ soil to prevent fines intrusion.	Stabilization Layer under Sediment Row & Scour Protection Layer
Recommended Geotextile Weights	4oz or heavier for embedment backfill sized ¾” – 1 ½”, 6oz for embedment backfill sized 1 ½” – 2”.	6oz used for all

Table 1 - Suitable Geotextiles

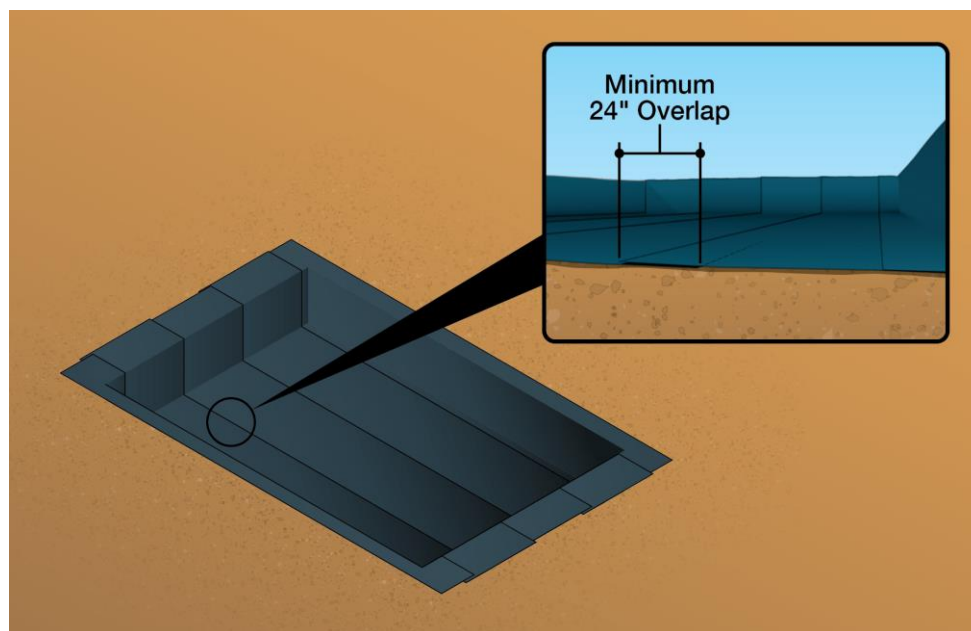

Figure 6 - Filter Fabric Installation

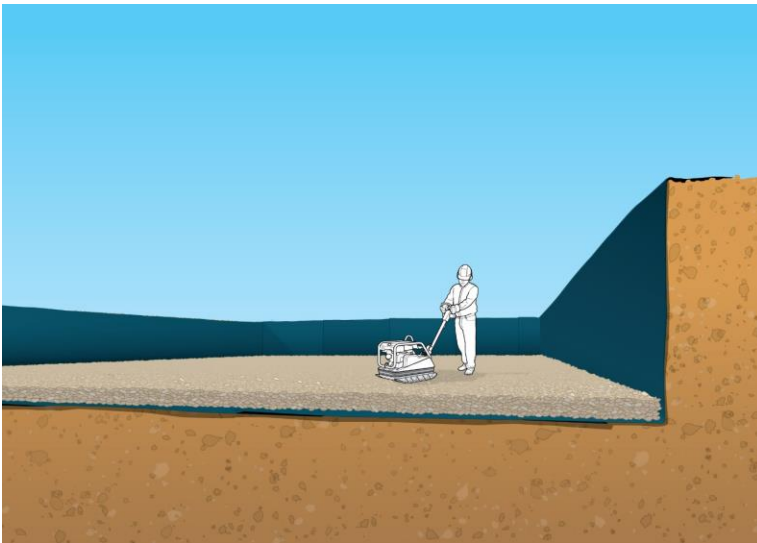

Figure 7- Bedding Compaction with Plate Compactor

After the fabric has been laid out, place a level bedding of $\frac{3}{4}$ "-2" washed, crushed, angular stone over the entire excavated bottom. **The bedding thickness shall be a minimum of 9" for the HS180 chamber and a minimum of 6" for the HS75.** Using a vibratory roller, compact the stone bedding to achieve a flat level surface.

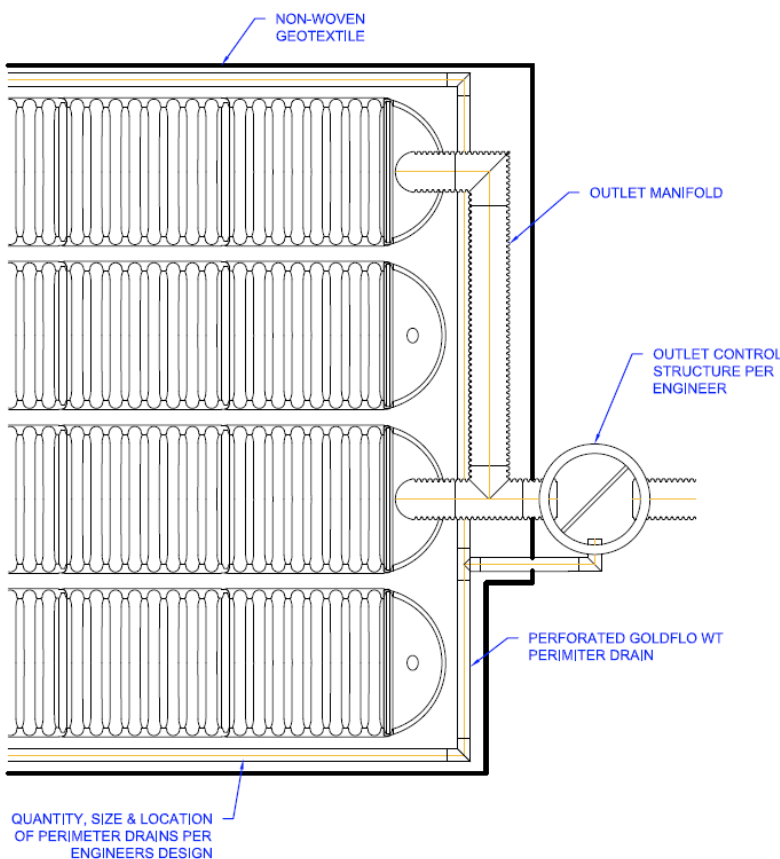

Figure 8 - Optional Perimeter Drain

If specified on the project plans, the perimeter underdrain piping may be laid at this point. The perimeter underdrain is to be installed around the chamber system and should not be placed under a chamber footing. Refer to the Perimeter Drain Detail Drawing for more information about perimeter drain installation.

Inlet Manifold Assembly and Chamber Placement

Upstream of the chamber system, an inlet structure should be installed. This structure will divert the water through a pre-treatment system, such as a Prinsco Stormwater Quality Unit (SWQU) and/or a chamber sediment row.

A manifold is used to distribute the stormwater to the chamber rows. A manifold system will typically consist of Prinsco GOLDFLO dual wall pipe and fittings. Pipe and fittings may be joined using split-band couplers. Lay out the manifold system using the project plans and appropriate details.

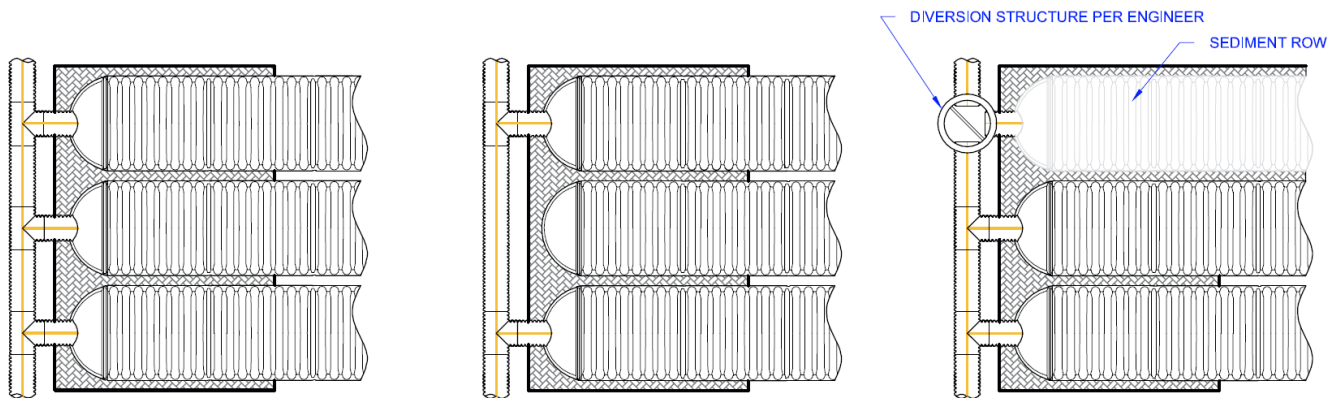

FIGURE 1. INLET MANIFOLD WITH STUBS INTO END CAP OF EACH STORM CHAMBER ROW.

FIGURE 2. INLET MANIFOLD WITH STUBS INTO END CAP OF ALTERNATING STORM CHAMBER ROWS.

FIGURE 3. DIVERSION STRUCTURE PER ENGINEER TO DIRECT INITIAL/LOW FLOW TO SEDIMENT ROW AHEAD OF INLET MANIFOLD.

Figure 9 - Inlet Manifold Options

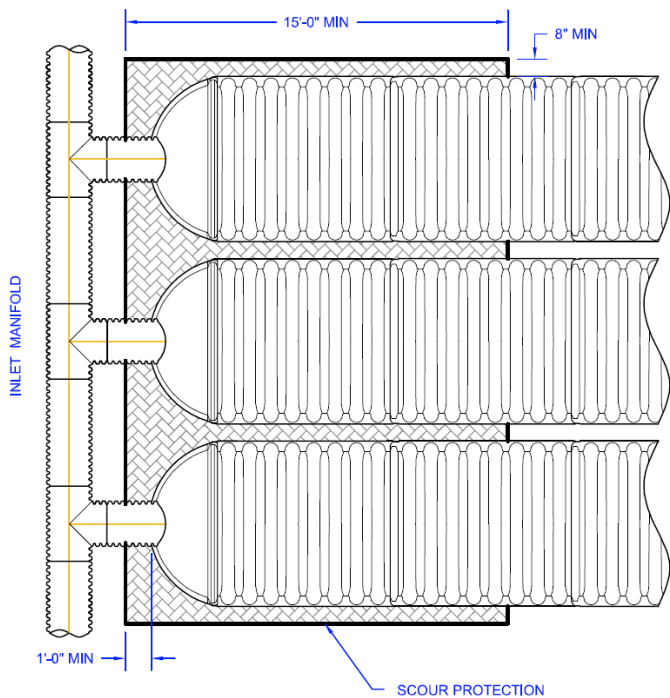

Figure 10 - Inlet Scour Protection

To alleviate the potential for scour at the inlet locations, lay a 15' wide strip of an AASHTO M288 Class 1 woven stabilization geotextile, along the entire length of the manifold mainline, adequately covering the bedding beneath the inlet locations. The fabric should extend a minimum of 12" in front of the end caps and 8" on the sides of the chambers.

Position the end caps of each row with the inlet pipes. At the required locations/elevations, core an opening in the end cap the approximate outside diameter of the pipe and insert the inlet pipe. The inlet pipe should penetrate 12" into the end cap.

Repeat this process for each row. Cover any open void spaces greater than $\frac{3}{4}$ " on the end caps with a non-woven geotextile to prevent infiltration of the backfill material.

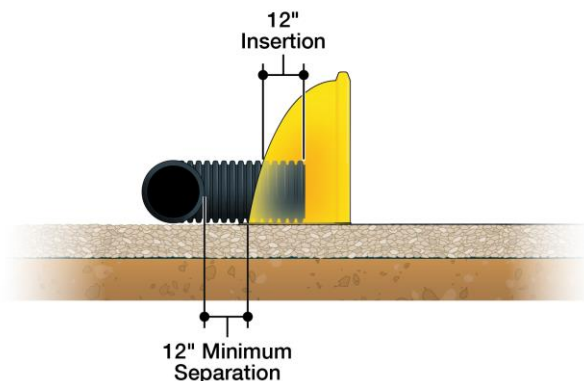

Figure 11 - Manifold / End Cap Connection

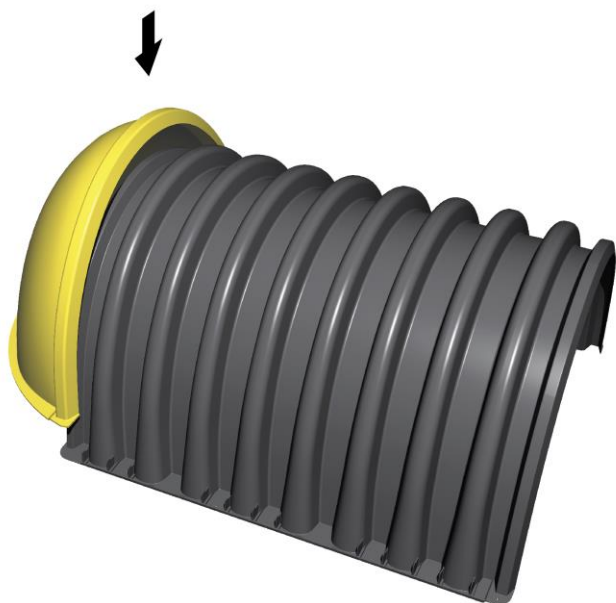

Figure 12 - End Cap Assembly

Position the chambers in line with the endcaps. Note the orientation of the chambers. The chambers are stamped with arrows showing the direction for installation. The end caps will fit over the first rib of the chambers. The end caps should be fastened to the chambers with a minimum of 4 evenly spaced screws or fasteners to keep the end caps from shifting during the backfilling process.

The assembly of each row is achieved by overtopping the last rib of the initial chamber with the first rib of the succeeding chamber.

Each chamber is marked with the overlap locations as well as the installation direction. During the assembly process do not extend the chamber rows beyond the reach of the backfill placement equipment. Endcaps shall be used to terminate each row.

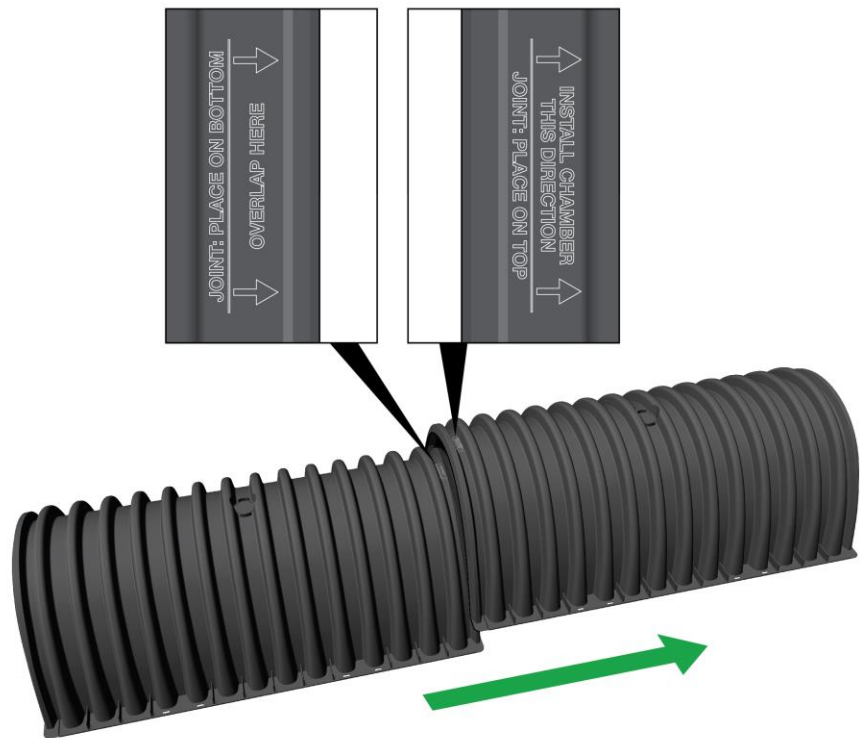

Figure 13 - Chamber Joint Assembly

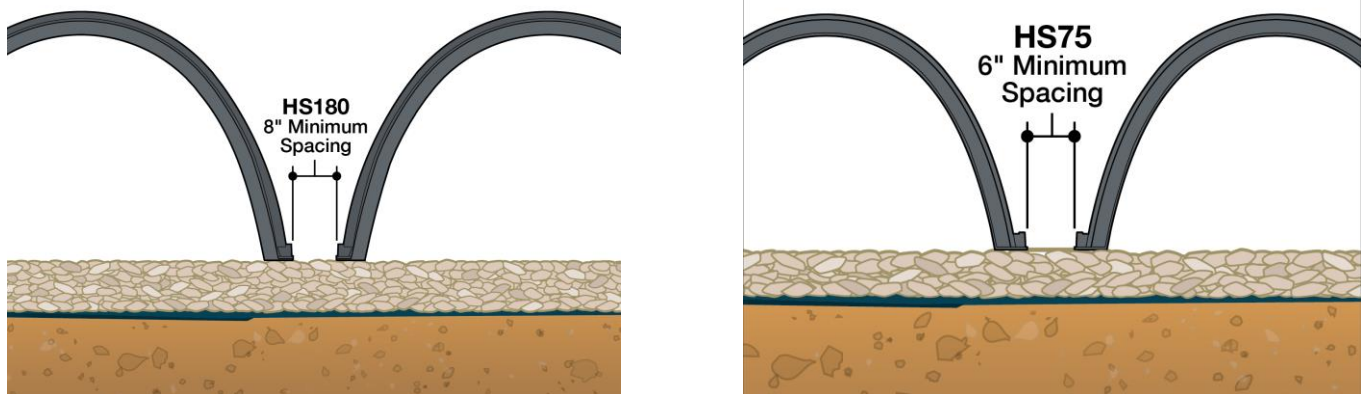

Figure 14 - Minimum Chamber Row Spacing

Maintaining an 8" minimum clear space for the HS180 and a 6" minimum clear space for the HS75 between each row is required for adequate structural support. A brick or other spacer is recommended to maintain the required spacing between the chamber feet.

Chamber Outlet Options

The purpose of the outlet is to ensure that there are free-flowing conditions between the chambers and the outlet control structure. Several possible outlet configurations are: An outlet manifold consisting of pipe stubs connected to the chamber end caps in the same fashion as the inlet manifold, a perimeter underdrain connected to the outlet control structure or a combination of both. The outlet control structure should be designed so that there is sufficient outflow from the chambers while allowing the chambers to reach full storage capacity. The outlet manifold sizing and configuration will vary based on the system sizing and requirements. Below is a typical outlet manifold configuration.

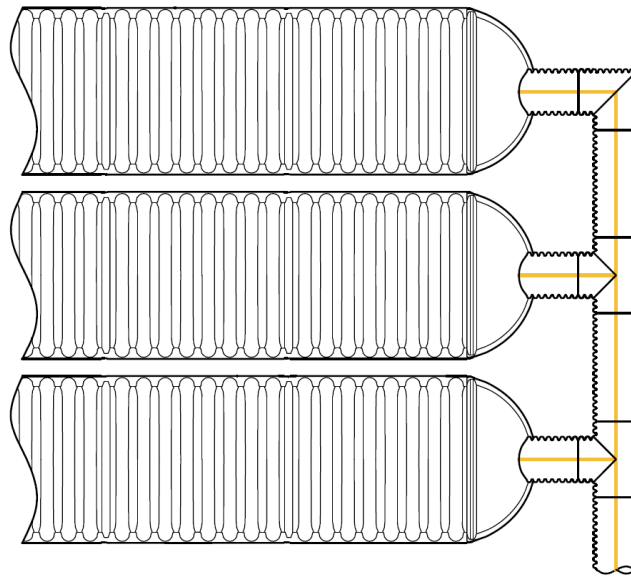

Figure 15 - Outlet Manifold Configuration

Pre-treatment / Sediment Row

Considering chambers have open bottoms, it is essential to utilize a pretreatment system to remove sediment and debris before the influent enters the chamber system. If the incoming effluent is untreated, the storage performance and service life of the system will be compromised. Prinsco recommends pretreatment of the stormwater runoff by using either a water treatment device such as the Prinsco Stormwater Quality Unit (SWQU) and/or a chamber sediment row. It is important to consider the local water quality regulatory requirements and the expected influent contamination.

Stormwater Quality Unit Option

- Pretreatment devices such as Prinsco's SWQUs should be installed upstream of the chamber system to treat the initial stormwater runoff before it reaches the chamber system. Prinsco offers several standard units and also has the ability to customize units to meet the job specific requirements. Refer to Prinsco's SWQU Product Detail & Bypass Detail for more information.

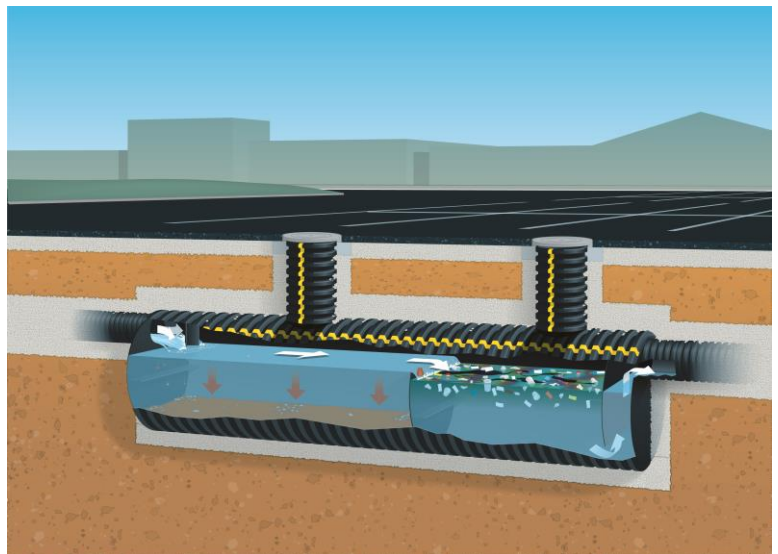

Figure 16 - Prinsco Stormwater Quality Unit (SWQU)

Sediment Row Option

- The Sediment Row consists of a series of chambers installed directly on top of two layers of woven geotextile. The geotextile serves as a filter and prevents the sediment from clogging the bedding. The specified geotextile is also durable enough to withstand cleaning and maintenance procedures using water jet technology.
- The sediment row is designed with an access structure upstream of the inlet. The access structure should be installed prior to the placement of the chambers. The structure will be designed to divert the initial stormwater runoff to the sediment row. Flows that exceed the capacity of the sediment row will then be diverted to the system through the inlet manifold.
- Installation of the sediment row may begin after the bedding has been placed. For detailed layout dimensions, refer to the Engineer's layout or Prinsco's standard Sediment Row detail.
- Two strips (8.3' wide for the HS180 and 5' wide for the HS75) of an approved AASHTO M288 Class 1 woven stabilization geotextile shall be placed over top of the bedding. The chamber row is then installed directly on top of the two layers of fabric. It is recommended that these two geotextile layers do not include any joints, overlaps or seams.
- A short stub of pipe can be used to connect the manhole to the end cap of the sediment row. It is recommended that an 18" diameter pipe for the HS75 and a 24" diameter pipe for the HS180 be used to allow access to the sediment row for maintenance procedures.

- A non-woven geotextile is not needed over top of the chambers since the chamber side walls are not perforated.
- After placement of the adjacent chamber rows, backfilling may commence as described in this guide.

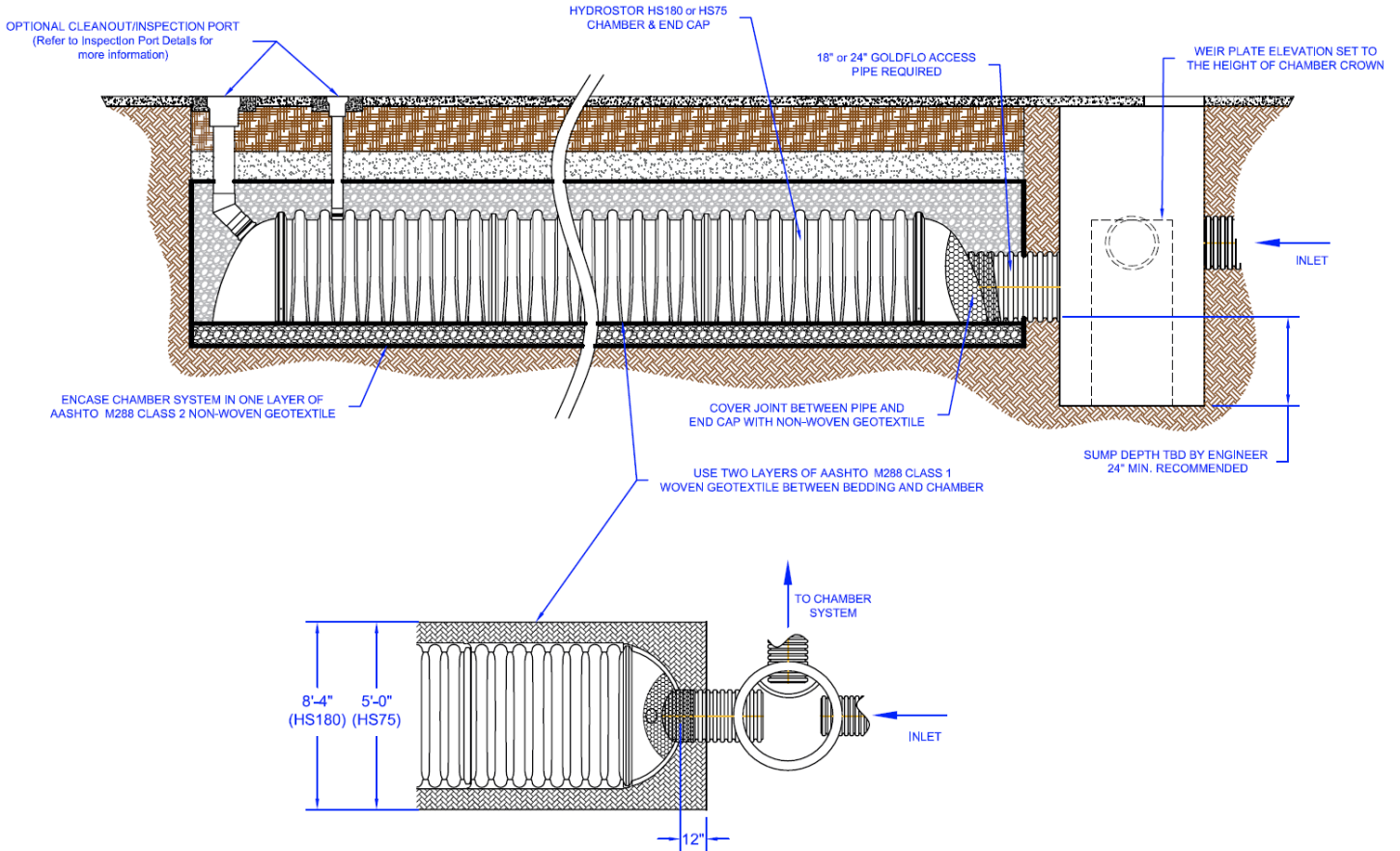

Figure 17 - Sediment Row

Vent / Inspection Port Placement

Inspection ports are not required for chambers systems, however they may be installed to monitor the sediment and debris level within the system. Using the project plans, identify which chambers should be fitted with inspection ports.

For the HS180 chamber, a 4" vent/inspection port may be placed in the valley between the corrugations. If a 6" or 8" inspection port is required, it should be placed on the end cap. The HS75 chamber is equipped with a circular cut out point in the center of the chamber to accommodate a 4" diameter inspection port.

Using a hole saw, cut out the opening at the appropriate location. A tap tee connection can be used to connect Sch. 40 or SDR 35 PVC pipe and fittings to build the inspection port as shown in Figure 18.

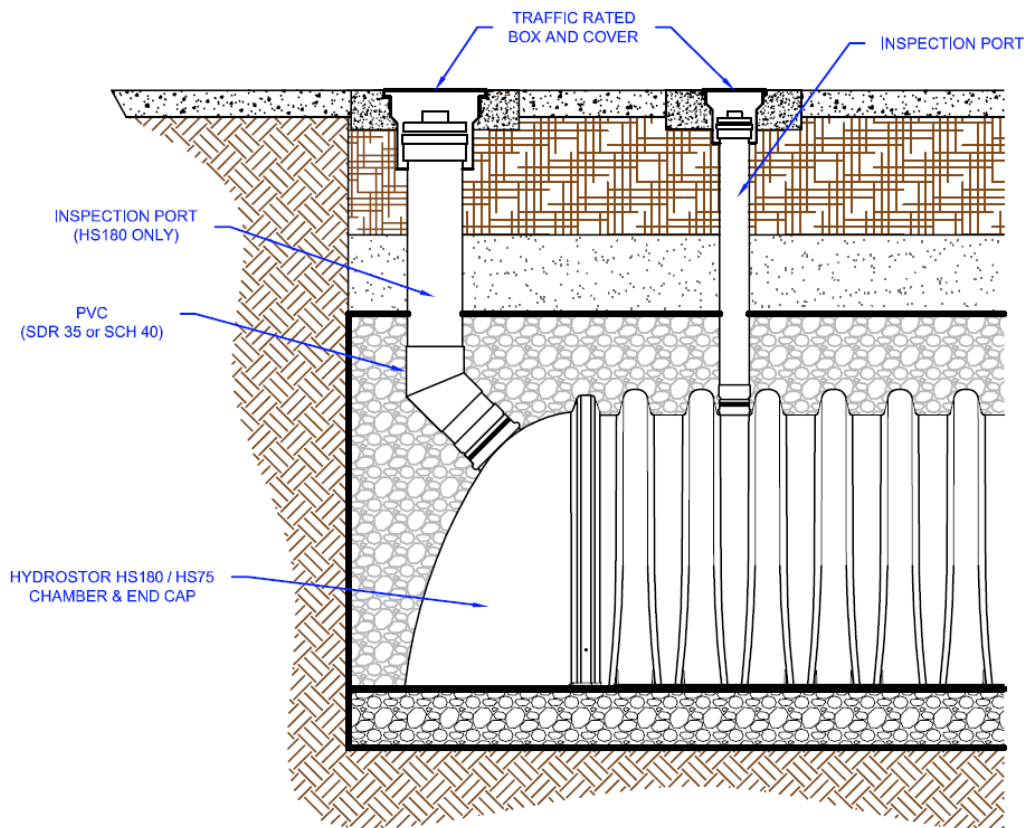

Figure 18 - Inspection Ports

Chamber Backfill Requirements

The backfilling process is critical to ensure long-term, trouble free operation of the chamber system. The backfill and chambers function together as a structural system to support the soil overburden and vehicular live loads. Therefore proper backfill material selection and placement is critical. Refer to Table 2 for acceptable backfill material selection.

Fill Material Location	Material Description	AASHTO M43 Designation
[D] Final Backfill- Fill material for Layer D starts at the top of the C layer to the bottom of the pavement or to the finished grade of an unpaved surface. The pavement subbase may be part of the final backfill.	Any backfill which provides adequate subgrade for the project per the engineer's plans. Plans shall indicate subgrade requirements.	N/A
[C] Initial Backfill- Material for layer C starts at the top of the embedment zone (layer B) and continues to 24" above the top of the chamber for the 25HC and 18" for the 11HC. The pavement subbase may be part of the initial backfill layer.	Well graded granular material, <35% fines.	AASHTO M45 A-1, A-2, A-3 or AASHTO M43 3, 357, 4, 467, 5, 56, 57, 6, 67, 68, 7, 78, 8, 89, 9,10
[B] Embedment Stone- Embedment stone will surround the chambers and extends from the top of the bedding stone (layer A) to the bottom of the fabric layer.	3/4" to 2" washed, crushed, angular stone.	AASHTO M43 3, 357, 4, 467, 5, 56, 57
[A] Bedding Stone- Bedding Stone extends from the sub grade to the foot of the chambers.	3/4" to 2" washed, crushed, angular stone.	AASHTO M43 3, 357, 4, 467, 5, 56, 57

Table 2 – Acceptable Backfill Materials

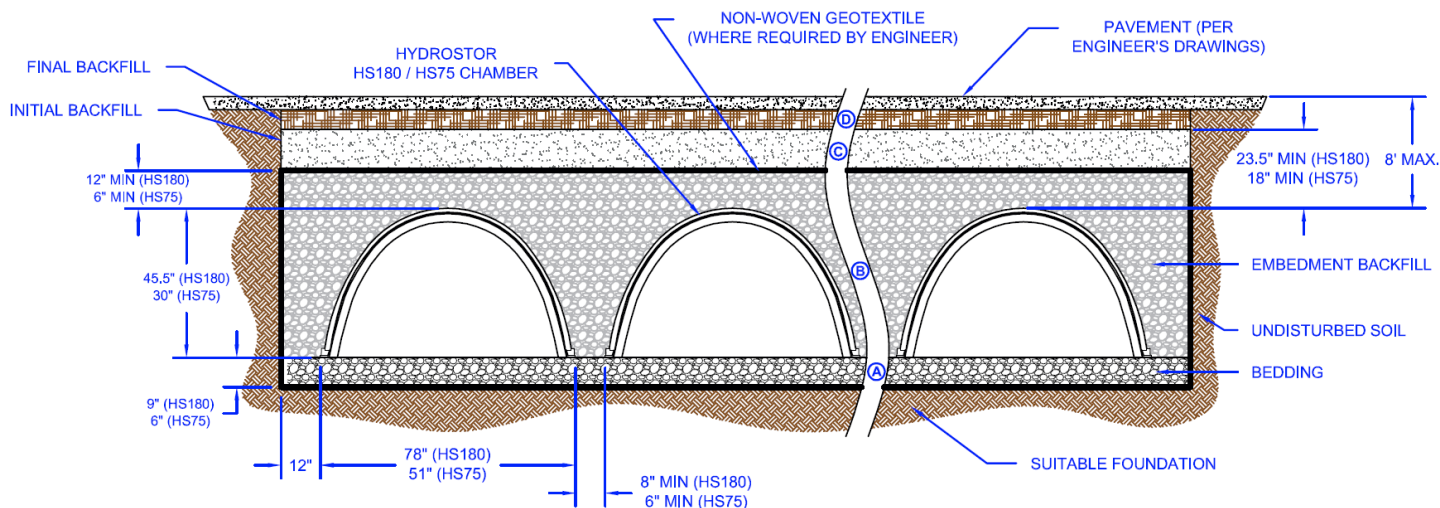

Figure 19 - Chamber Cross Section

Backfill material used for embedment, anchoring and for surrounding areas should comprise of a ¾"-2", washed, crushed angular stone. Placement of backfill material for embedment and surrounding areas is best accomplished by using the long reach of an excavator or stone shooter/conveyor system. **No construction equipment shall be situated on top of the chamber system without the minimum embedment backfill placed over the chambers (12" for HS180 & 6" for HS75).** Compaction of the crushed stone around the chambers is not required, however, it is critical to ensure that the backfill is adequately knifed in around the manifolds and between the chamber corrugations.

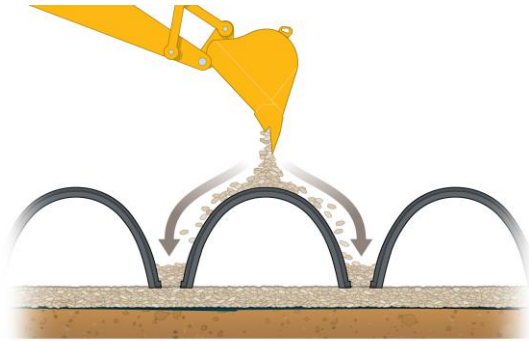

Figure 20 - Backfill Placement with Excavator

In order to prevent chamber shifting and to maintain the appropriate row spacing (8" for HS180, 6" for HS75), carefully deposit the stone evenly along the centerline of the chamber, allowing the stone depth between the rows to rise equally. During this phase, stone height between rows should not differ by more than 12" at any time.

After the anchoring phase is complete, stone placement may continue to surround the chambers and around the perimeter. The embedment backfill stone should fully encompass the chambers and should continue over the top the chamber crown to a minimum height of 12" for the HS180 chambers and 6" for the HS75 chambers. The backfill should also extend evenly from the chambers to the sidewalls of the excavation.



Figure 21 - Embedment Stone Placement



Figure 22 - Perimeter Backfill Placement

After the required embedment backfill thickness has been placed on top of the chambers (12" for HS180 & 6" for HS75), a small light weight tracked dozer with ground pressure less than 1100 lbs/sf may be used to finalize the grading of cover stone. Stone must be pushed parallel to the chamber rows at all times. **Wheel and Roller Loads are Not Allowed.**

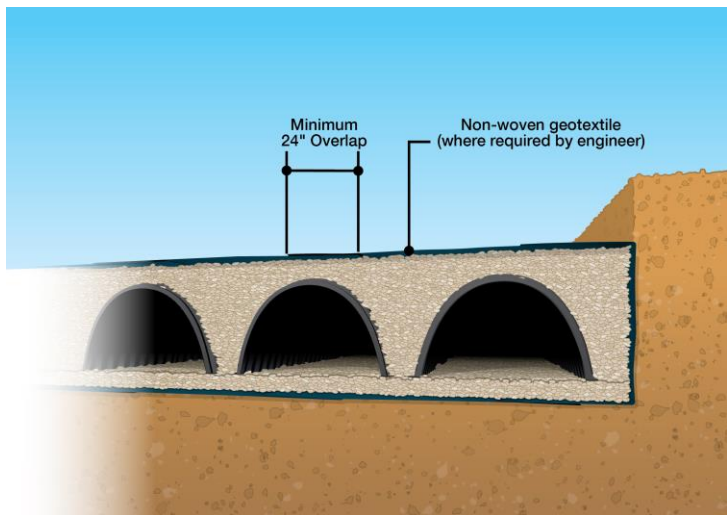

Figure 23 - Filter Fabric over Top of Chambers

After the embedment backfill has been evenly spread over the top of the chambers, the entire top of the stone bed should be covered with a layer of 4 or 6 oz. non-woven fabric. All seams should be overlapped a minimum of 24”.

Utilizing an excavator positioned next to the chamber rows, the initial backfill can now be placed over top of the fabric. After the minimum required initial backfill over top of the chambers has been placed (total cover of 23.5” for HS180 & 18” for HS75), compaction of the backfill may begin. It is recommended that the compaction

equipment travels parallel with chamber rows. Refer to Table 3 for Backfill Compaction Recommendations and to Table 4 for the maximum allowable construction loads.

Fill Material Location	Placement Methods / Restrictions	HS180 Compaction Requirements	HS75 Compaction Requirements
[D] Final Backfill	A variety of placement methods may be used. All construction loads must not exceed the limits in Table 4.	Subgrade will be placed and compacted to the requirements as shown on the site plans.	Subgrade will be placed and compacted to the requirements as shown on the site plans.
[C] Initial Backfill	Use of an excavator positioned off bed is recommended. Small excavators and small dozers may be allowed based on the information in Table 4.	Compaction will not begin until a minimum of 24" of material is placed over the chambers. Additional layers shall be compacted in 12" lifts to a minimum of 95% standard proctor density for well graded material.	Compaction will not begin until a minimum of 12" of material is placed over the chambers. Additional layers shall be compacted in 6" lifts to a minimum of 95% standard proctor density for well graded material. Roller gross vehicles are not to exceed 12,000 lbs. and dynamic force not to exceed 20,000 lbs.
[B] Embedment Stone	No equipment is allowed on bare chambers. Use excavator or stone conveyor positioned off bed to evenly place the backfill around and on top of all of the chambers.	No compaction required.	No compaction required
[A] Bedding Stone	Placement with a variety of equipment is acceptable to provide a stable, level base.	Placed in 9" lifts and compacted with a vibratory roller.	Placed in 6" lifts and compacted with a vibratory roller.

Table 3 - Backfill Placement & Compaction Recommendations

Minimum and Maximum Cover Heights

A minimum of 23.5” of cover for the HS180 chamber & 18” for the HS75 chamber, measured from the top of the chambers to the bottom of pavement, is recommended for H-20 vehicle loading. If pavement is not to be used, the cover should be increased to a minimum 30” of cover for H-20 vehicular loading.

If the chambers will experience loading from construction equipment while the project is still being constructed, temporary fill may be placed over the system during construction and removed after the heavy construction equipment traffic is rerouted. Refer to Table 4 for maximum allowable construction vehicle loads at various backfill depths.

The maximum burial depth for HS180 & HS75 chambers is 8 feet. The cover height is measured from the top of the chambers to the top of the pavement or final backfill layer if pavement is not present.

Material Location	Fill Depth above chambers (in.)	Max Allowable Wheels Loads		Max Allowable Track Loads		Max Allowable Roller Loads
		Max Axle Load for Trucks (lbs)	Max Wheel Load for Loaders (lbs)	Track Width (in)	Max Ground Pressure (psf)	Max Drum Weight Dynamic Force (lbs)
[D] FINAL FILL MATERIAL	36" COMPACTED	32,000	16,000	12"	3420	38,000
				18"	2350	
				24"	1850	
				30"	1510	
				36"	1310	
[C] INITIAL FILL	24" COMPACTED	32,000	16,000	12"	2480	20,000
				18"	1770	
				24"	1430	
				30"	1210	
				36"	1070	
	24" DUMPED	24,000	12,000	12"	2245	16,000 for HS180 20,000 for HS75 Gross weight of roller not to exceed 12,000lbs
				18"	1625	
				24"	1325	
				30"	1135	
	18"	24,000	12,000	12"	2010	5,000 for HS180 20,000 for HS75 Gross weight of roller not to exceed 12,000lbs
				18"	1480	
				24"	1220	
30"				1060		
[B] EMBEDMENT ZONE	12"	NOT ALLOWED	NOT ALLOWED	12"	1100 (1540 for HS75)	NOT ALLOWED
				18"	715 (1190 for HS75)	
				24"	660 (1010 for HS75)	
				30"	580 (910 for HS75)	
	6"	NOT ALLOWED	NOT ALLOWED	12"	NOT ALLOWED (1070 for HS75)	NOT ALLOWED
				18"	NOT ALLOWED (900 for HS75)	
				24"	NOT ALLOWED (800 for HS75)	
				30"	NOT ALLOWED (760 for HS75)	

Table 4 - Maximum Allowable Construction Vehicle Loads



When it comes to stormwater chambers, the road from good to great leads directly to HydroStor, the industry's newest, high performance chamber line. Chambers systems are a highly effective way to maximize commercial land usage by providing underground stormwater storage & recharge.

HS180

11.5" minimum	backfill above chamber	6" minimum
9" minimum	bedding	6" minimum
8"	chamber spacing	6"
78"	chamber width	51"
12"	backfill at edge of system	12"
45.5"	chamber height	30"
23.5"	minimum cover	18"
8'	maximum burial depth	8'

HS75

Available Sizes



HS180

180 ft ³ /chamber	Installed Storage Capacity
45"	Height
77.8"	Width
88.7"	Length



HS75

75 ft ³ /chamber	Installed Storage Capacity
30"	Height
51"	Width
85.4"	Length
Integrated Handles	Special Features
Meets or Exceeds	ASTM Standards

The HydroStor **HS180** stores 25 cubic feet of stormwater per linear foot or 180 cubic feet per chamber, and is designed for high-volume projects.

The HydroStor **HS75** stores 11 cubic feet per linear foot or 75 cubic feet per chamber and is designed for projects with limited burial depths.

Both chambers meet rigorous ASTM standards and include value-added design features that take this new chamber option from good to great.

Performance

- Meets or exceeds ASTM F2418 & ASTM F2787
- Meets AASHTO live & earth load requirements
- High performance polypropylene
- Advanced injection molding for extreme structural performance

MOBILE RESOURCES



More about **HydroStor™**
 Installation Videos
 Installation Documents
 Specifications
 Technical Notes



Prinsco.com/HydroStor-resources

ENGINEERED WITH INTEGRITY

Prinsco products are fully supported by our engineering team and are designed, manufactured and tested to meet/exceed the high performance needs of the construction market. Prinsco's engineering, quality control and production teams are committed to a continuous process of innovation, product development and quality improvement. We are focused on environmental sustainability, water quality, stormwater management and performance advancement.

COLLECTION & CONVEYANCE



GOLDFLO®
AASHTO Dual-Wall Pipe

ECOFLO® 100
High Performance
Recycled Dual-Wall Pipe

TREATMENT



STORMWATER QUALITY
Water Treatment

STORAGE



HYDROSTOR™
High Performance
Arched Chambers

UNDERGROUND DETENTION
Customized High Performance
Pipe Systems



PRINSCO.COM
Your Resources. One Stop. Any Device.

800.992.1725