

Chamber Specifications	
Chamber Size (L x W x H)	87.1" x 51.0" x 29.7" (2,212 x 1,295 x 754 mm)
Installed Length	84.9" (2,155 mm)
Chamber Storage	46.4 ft ³ (1.31 m ³)
Min. Installed Storage*	74.9 ft ³ (2.12m ³)
Weight / Chamber	70 lbs (32 kg)
Chambers / Pallet	33
Approx. Weight / Pallet	2,500 lbs (1,134 kg)

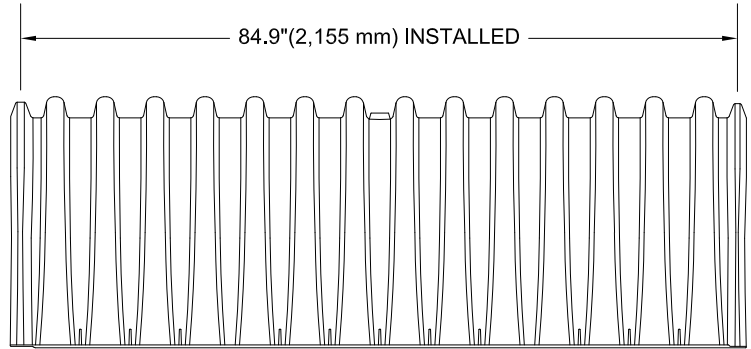

End Cap Specifications	
End Cap Size (L x W x H)	11.6" x 48.1" x 29.4" (295 x 1,222 x 747 mm)
Installed Length	8.0" (203 mm)
End Cap Storage	2.75 ft ³ (0.08 m ³)
Min. Installed Storage*	12.02 ft ³ (0.34 m ³)
Weight	12 lbs (5.44 kg)

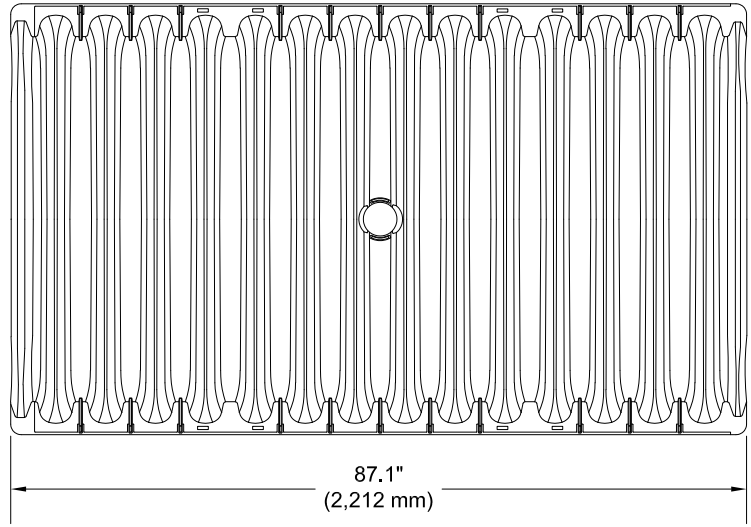
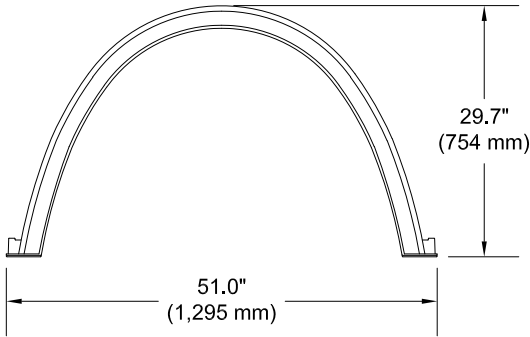
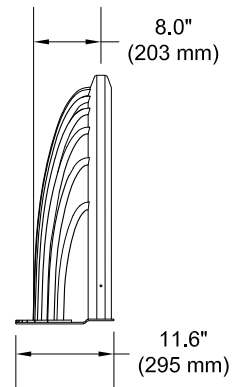
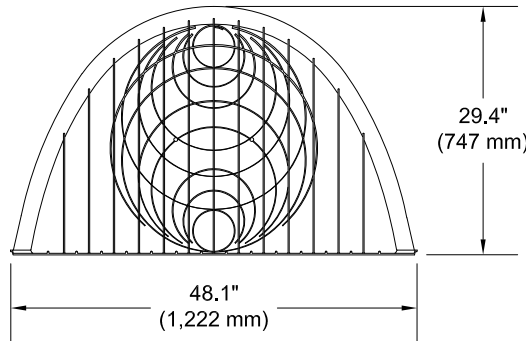

*ASSUMES 6" (150 mm) STONE ABOVE CHAMBERS/END CAPS, 6" (150 mm) OF STONE FOR FOUNDATION STONE, 6" (150 mm) OF STONE BETWEEN CHAMBERS/END CAPS, 12" (300 mm) OF STONE PERIMETER IN FRONT OF END CAPS AND 40% STONE POROSITY.

THIS DETAIL DEPICTS RECOMMENDED INSTALLATION PRACTICES AND IS NOT INTENDED TO SUPERSEDE ANY NATIONAL, STATE OR LOCAL SPECIFICATIONS. PRINSCO BEARS NO RESPONSIBILITY FOR ANY ALTERATIONS, REVISION AND/OR DEVIATION FROM THIS STANDARD DETAIL. PRINSCO HAS NOT PERFORMED ANY ENGINEERING OR DESIGN SERVICE FOR THIS PROJECT. THE DESIGN ENGINEER SHALL REVIEW THESE DETAILS PRIOR TO CONSTRUCTION TO VERIFY SUITABILITY. © PRINSCO, INC.



1717 16TH ST. NE
WILLMAR, MN 56201
www.prinSCO.com

TITLE: HYDROSTOR HS75 - SPECIFICATION		REV: B
DRAWN BY: ARB	DATE: 05-Jun-17	DRAWING NUMBER: D-7-301
SCALE: NTS	SHEET: 1 OF 1	