

**NOTES:**

1. HYDROSTOR HS75 CHAMBERS SHALL BE DESIGNED IN ACCORDANCE WITH ASTM F2787 AND SHALL CONFORM TO THE REQUIREMENTS OF ASTM F2418. HS75 CHAMBERS SHALL BE INSTALLED IN ACCORDANCE WITH THE MANUFACTURER'S LATEST INSTALLATION GUIDELINES.
2. **GEOTEXTILE:** TWO DIFFERENT GEOTEXTILES WILL BE USED IN CREATING A FUNCTIONING SEDIMENT ROW. TO ENSURE FABRIC IS SUITABLE WITH IN SITU SOILS, A GEOTECHNICAL ENGINEER SHOULD BE CONSULTED.
  - AN AASHTO M288 CLASS 2 OR 3 NON-WOVEN GEOTEXTILE SHOULD BE USED FOR EMBEDMENT BACKFILL MATERIAL 3/4 TO 2 INCH (19 - 51 MM). GEOTEXTILE FILTER FABRIC IS PLACED AROUND THE SYSTEM TO PREVENT NATIVE SOIL FROM MIGRATING INTO THE EMBEDMENT BACKFILL MATERIAL. TO ENSURE FABRIC IS SUITABLE WITH IN SITU SOILS, A GEOTECHNICAL ENGINEER SHOULD BE CONSULTED.
  - TWO LAYERS OF AN AASHTO M288 CLASS 1 WOVEN FABRIC IS PLACED BETWEEN THE BEDDING AND THE CHAMBER FOR THE CREATION OF THE SEDIMENT ROW. THE TWO LAYERS PROVIDE A PROTECTIVE BARRIER FOR THE EMBEDMENT BACKFILL BUT STILL ALLOWING WATER TO INFILTRATE INTO THE SYSTEM. THE WOVEN GEOTEXTILE IS DURABLE ENOUGH TO ALLOW JETTING TO CLEAN THE SEDIMENT ROW.
3. **INSPECTION AND MAINTENANCE:** INSPECTION OF THE SYSTEM SHOULD OCCUR BIANNUALLY TO ENSURE LARGE AMOUNTS OF SEDIMENT OR DEBRIS HAVE NOT BEEN DEPOSITED IN THE SEDIMENT ROW. DURING THE FIRST YEAR, INSPECTION SHOULD OCCUR MORE FREQUENTLY DUE TO CONSTRUCTION SEDIMENT LOADING. TO CLEAN THE SYSTEM, A JET/VAC PROCESS CAN BE USED TO REMOVE SEDIMENT AND DEBRIS FROM THE SEDIMENT ROW. FOR MORE INFORMATION, REFER TO PRINSCO'S "RETENTION/DETENTION CLEANING AND MAINTENANCE" TECHNICAL NOTE.
4. **ACCESS PIPE:** PRINSCO RECOMMENDS A 24 INCH (600 mm) DIAMETER ACCESS PIPE TO THE SEDIMENT ROW. A 24 INCH (600 mm) INTERNAL SLEEVE ADAPTER (PART # HS75A-24) WILL BE REQUIRED TO CONNECT TO HS75 END CAPS. CONTACT YOUR LOCAL SALES REPRESENTATIVE WITH ANY QUESTIONS.

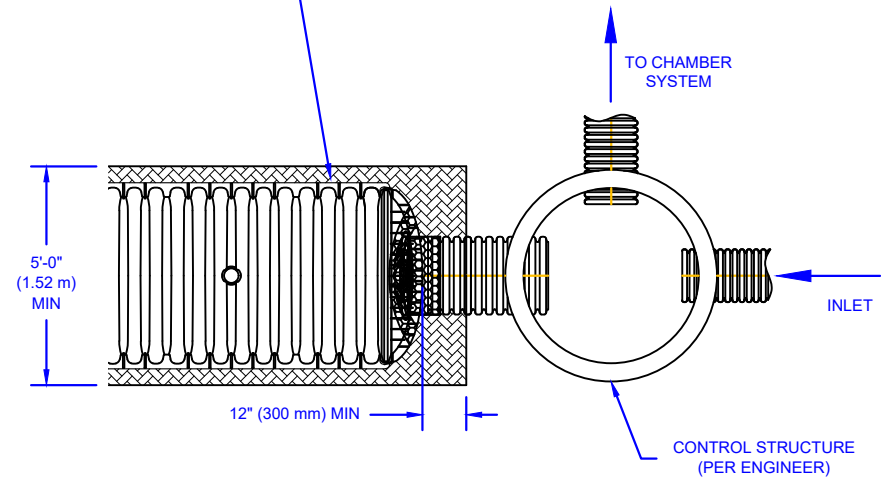

THIS DETAIL DEPICTS RECOMMENDED INSTALLATION PRACTICES AND IS NOT INTENDED TO SUPERSEDE ANY NATIONAL, STATE OR LOCAL SPECIFICATIONS. PRINSCO BEARS NO RESPONSIBILITY FOR ANY ALTERATIONS, REVISION AND/OR DEVIATION FROM THIS STANDARD DETAIL. PRINSCO HAS NOT PERFORMED ANY ENGINEERING OR DESIGN SERVICE FOR THIS PROJECT. THE DESIGN ENGINEER SHALL REVIEW THESE DETAILS PRIOR TO CONSTRUCTION TO VERIFY SUITABILITY. © PRINSCO, INC.



1717 16TH ST. NE  
WILLMAR, MN 56201  
www.prinSCO.com

TITLE: HYDROSTOR HS75 - SEDIMENT ROW		
DRAWN BY: DJW	DATE: 03-Aug-21	DRAWING NUMBER:
SCALE: NTS	SHEET: 1 OF 1	D-7-302