

 **HydroStor**[™] | HS290

 **HydroStor**[™] | HS180

Design Guide



Table of Contents

Table of Contents.....	1
1.0 Introduction	2
2.0 Product Information.....	3
3.0 Structural Design	8
4.0 Subsurface Foundation Requirements.....	9
5.0 Installed Storage Volumes for HydroStor Chambers.....	11
6.0 Required Materials for Installation	16
7.0 Stormwater Flow into Chambers	19
8.0 Outlet from HydroStor Chamber Systems.....	24
9.0 Other Considerations	26
10.0 System Sizing.....	27
11.0 Structural Cross Sections and Specifications	30
12.0 Sediment Row Inspection & Maintenance.....	32
13.0 General Notes	33

The HydroStor chamber represents the most advanced engineering, molding, and structural performance in the storm water management industry. Prinsco can assist in specifying HydroStor stormwater systems based on the project needs. Our expertise includes chamber layouts designed to meet volume requirements as well as inflow and outflow requirements for the HydroStor chamber system. Prinsco is also capable of assisting with conversions from other traditional stormwater management systems such as pipe, above ground ponds, vaults, and other manufactured and natural systems. The design engineer is responsible for determining that the layout meets all required design elements and is in compliance with the regulations which cover the project. For more information contact your local Prinsco representative at 1-800-992-1725.

1.0 Introduction

1.1 Introduction

The HydroStor chamber system was developed to provide an alternative storm water management system for design professionals, which provides a more efficient means of managing stormwater runoff from developed land. The applications for the HydroStor system include commercial, residential, industrial, highway, and agricultural drainage. HydroStor chambers deliver a lower cost solution by providing excellent stormwater management with the ability to tailor the solution to site requirements.

The HydroStor system has been designed and manufactured to exceed the requirements of the American Society for Testing and Materials (ASTM) standards. The injection molded structures provide the most cost effective, structurally superior chambers for the underground stormwater management market.

1.2 Product Design

HydroStor chambers are designed to meet the requirements of Section 12.12 of the American Association of State Highway and Transportation Officials (AASHTO) Load and Resistance Factor Design (LRFD) Bridge Design Specifications. The chambers are injection molded and manufactured to meet the requirements of ASTM F2418 *Standard Specification for Polypropylene (PP) Corrugated Wall Stormwater Collection Chambers*. Additionally, HydroStor chambers are designed in accordance with ASTM F2787 *Standard Practice for Structural Design of Thermoplastic Corrugated Wall Stormwater Collection Chambers*. The requirements of these ASTM and AASHTO standards dictate that the chambers be in compliance with rigorous design and quality requirements. All HydroStor chambers are manufactured at ISO 9001 compliant facilities.

1.3 Technical Support

During the design and construction of any underground stormwater management structure, it is frequently necessary to provide technical support for the product being designed and installed. Prinsco's team is committed to providing technical and engineering support for HydroStor chamber systems, including assistance with volume calculations, layout of the chamber system, and installation guidance. For technical assistance, contact your local Prinsco representative by calling 1-800-992-1725.

2.0 Product Information

2.1 Applications

HydroStor chambers were designed to primarily function as a stormwater detention and retention structure. In addition, they deliver additional benefits by providing both water quality and water quantity management. HydroStor chambers are an ideal storage system that maintains above ground uses such as parking lots, roadways, and green space.

HydroStor chambers provide the maximum flexibility for use on a construction site. Chamber systems can be configured in large beds or in individual trenches and can be used on almost any site to provide the required storage and improve water quality. The chamber systems can be retrofitted to sites that have already been developed and can be designed to efficiently and easily work around utilities, structures and other boundaries.

2.2 Stormwater Detention

Chamber systems have been used in stormwater detention for several years. A detention system is primarily used to hold stormwater before it is released from the site, reducing the peak flow rates of the site and restoring flow rates to that of pre-development conditions. The HydroStor stormwater chamber system is an open bottom structure that allows infiltration of stormwater into the ground. Most chamber systems are designed to provide a detention system type of control. There are limiting circumstances such as soft subgrades, karst topography, and expansive clay subgrades where infiltration may be undesirable. In situations such as these, a geomembrane liner can provide an excellent alternative to limit infiltration.

2.3 Chamber Sizing

The primary determining factors when choosing a chamber size are the depth to groundwater, bedrock, depth to other restrictive surface, available area for the underground system, cover height required over the system, and outlet invert restrictions.

Because of differing site restrictions, HydroStor chambers are available in four sizes; two of which are detailed in this Design Guide due to similar installation properties. The HS180 has an installed capacity of 180 cubic feet (5.1 cubic meters) per chamber, based on a stone porosity of 40%. In many cases this is the optimal installation, especially for large footprints and limited vertical depth allowances for the installation.

For sites with slightly larger vertical room and a smaller horizontal footprint, the HS290 offers an excellent choice with an installed capacity of 110 cubic feet (3.1 cubic meters) chamber, based on a 40% stone porosity. This is the chamber of choice for tight sites with steep natural grades.

Illustrations of HydroStor HS180 and HS290 chambers and end caps are shown in Figures 1 and 2 below.



Chamber Specifications	
Chamber Size (L x W x H)	88.7" x 77.8" x 45.5" (2,253 x 1,976 x 1,156 mm)
Installed Length	85.3" (2,167 mm)
Chamber Storage	113.6 ft ³ (3.22 m ³)
Min. Installed Storage*	180.0 ft ³ (5.10 m ³)
Weight	127 lbs (57.6 kg)
Chambers / Pallet	19
Approx. Weight / Pallet	2,600 lbs (1,179 kg)

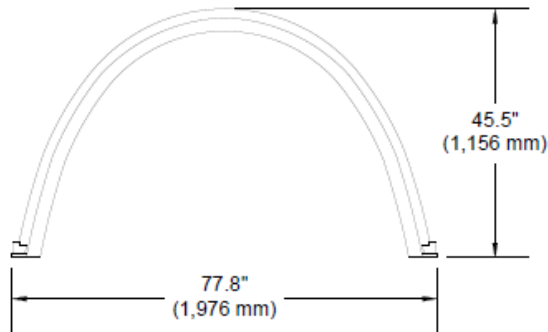
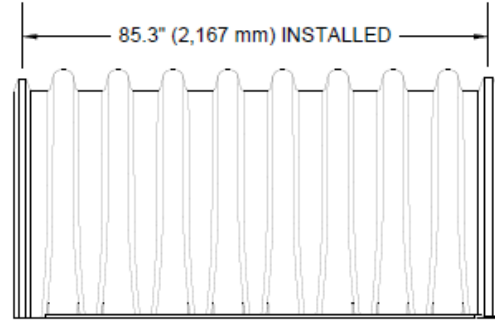
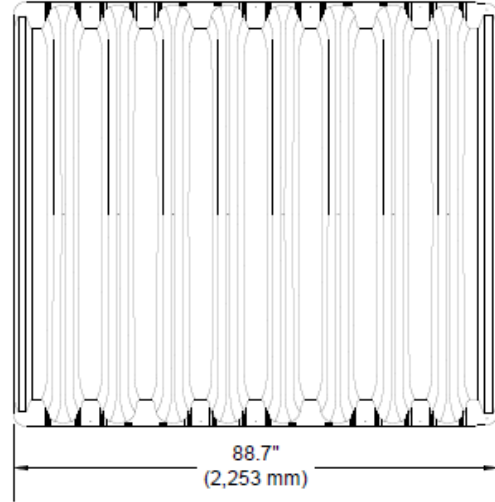

End Cap Specifications	
End Cap Size (L x W x H)	24.0" x 78.5" x 44.7" (609 x 1,994 x 1,136 mm)
Installed Length	22.1" (561 mm)
End Cap Storage	15.3 ft ³ (0.43 m ³)
Min. Installed Storage*	46.0 ft ³ (1.30 m ³)
Weight	52 lbs (23.6 kg)

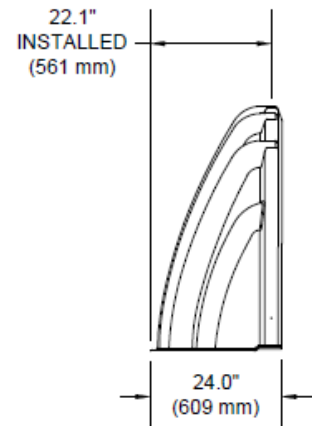
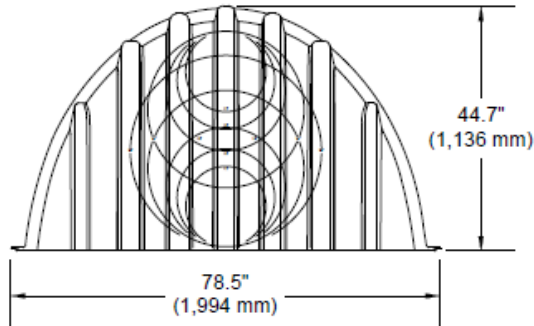
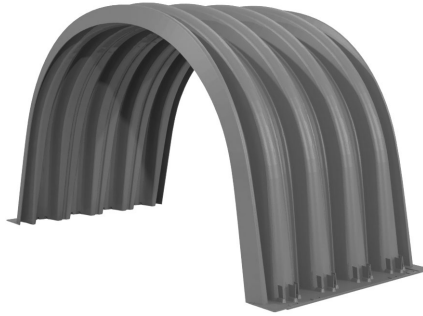
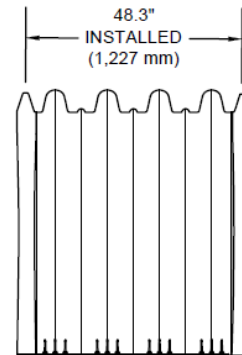
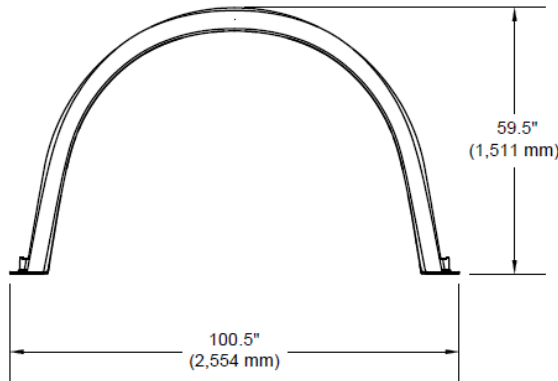
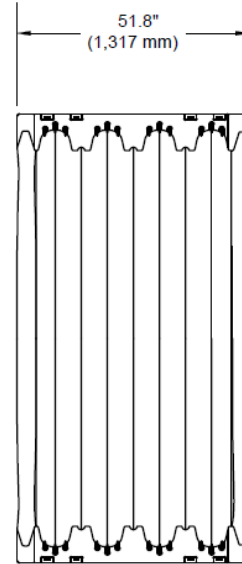

Figure 1 - HydroStor HS180 Chamber & End Caps



Chamber Specifications	
Chamber Size (L x W x H)	51.8" x 100.5" x 59.5" (1,317 x 2,554 x 1,511 mm)
Installed Length	48.3" (1,227 mm)
Chamber Storage	109.6 ft ³ (3.10 m ³)
Min. Installed Storage*	163.9 ft ³ (4.64 m ³)
Weight / Chamber	125 lbs (56.70 kg)
Chambers / Pallet	10
Approx. Weight / Pallet	0 lbs (0 kg)



End Cap Specifications	
End Cap Size (L x W x H)	35.0" x 94.0" x 59.3" (889 x 2,388 x 1,506 mm)
Installed Length	32.4" (823 mm)
End Cap Storage	39.7 ft ³ (1.12 m ³)
Min. Installed Storage*	109.5 ft ³ (3.10 m ³)
Weight	79.9 lbs (36.24 kg)

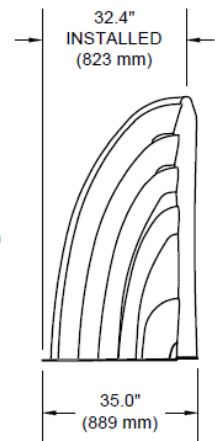
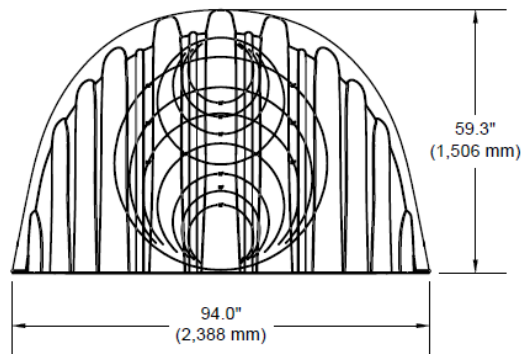

Figure 2 - HydroStor HS290 Chamber & End Caps

2.4 HydroStor Chambers

HydroStor Chambers are extremely versatile and can be configured as necessary to meet the site's needs. The chamber's versatility enables the chamber layout to be designed to appropriately meet the site conditions and avoid obstacles that may be interfering with a standard system layout. If a run of chambers must be interrupted, for instance, an end cap can be placed on the row's last chamber. The row can then be restarted after the interruption.

To ease construction and provide easy in-field guidance, each chamber is marked with overlap locations as well as the installation direction. (Figure 3) The assembly of each row is achieved by over topping the last rib of the initial chamber with the first rib of the succeeding chamber (Figure 4).

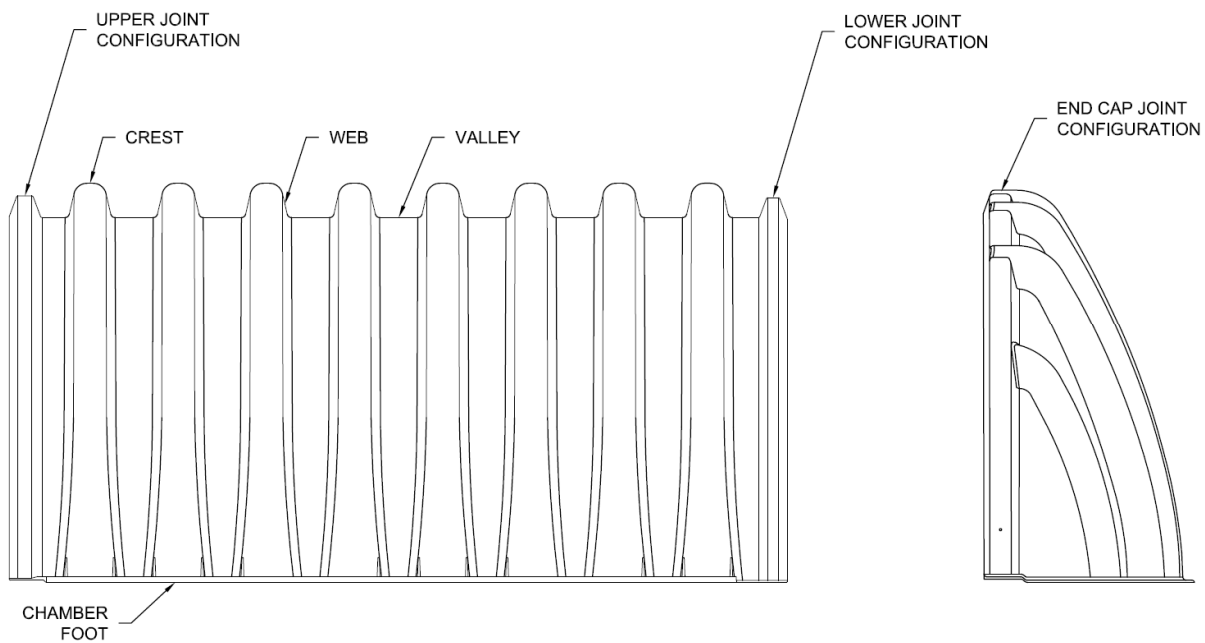

Figure 3 - Chamber and End Cap Components

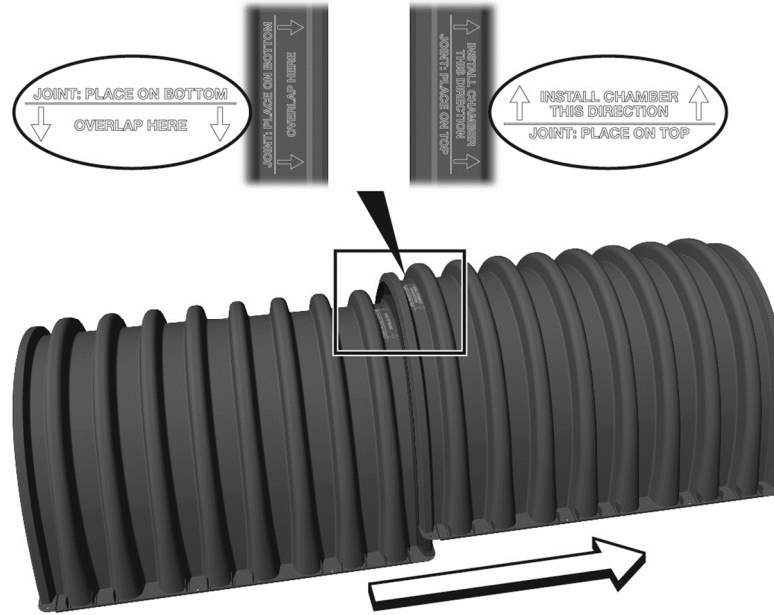

Figure 4 - Chamber Joint Assembly

2.5 End Caps

HydroStor end caps are designed to fit over either end of the chamber in order to terminate the chamber row. (Figure 3) Each end cap must be attached to the chamber by use of three (3) screws, one (1) on each side and one (1) into the top. The end caps are required to be placed at the end of each row in order to seal the chamber from the aggregate surrounding it. This requires two end caps per row to be ordered with each chamber system. End caps for the HS180 accept up to a 30" (750 mm) pipe without an adapter. End caps for the HS290 accept up to a 42" (1050 mm) pipe without an adapter. Illustrations of HydroStor HS180 and HS290 end caps are shown in Figures 1 and 2. Figure 5 shows each end cap with the scribe lines to be used for field cuts, with respect to pipe diameter and pipe invert.

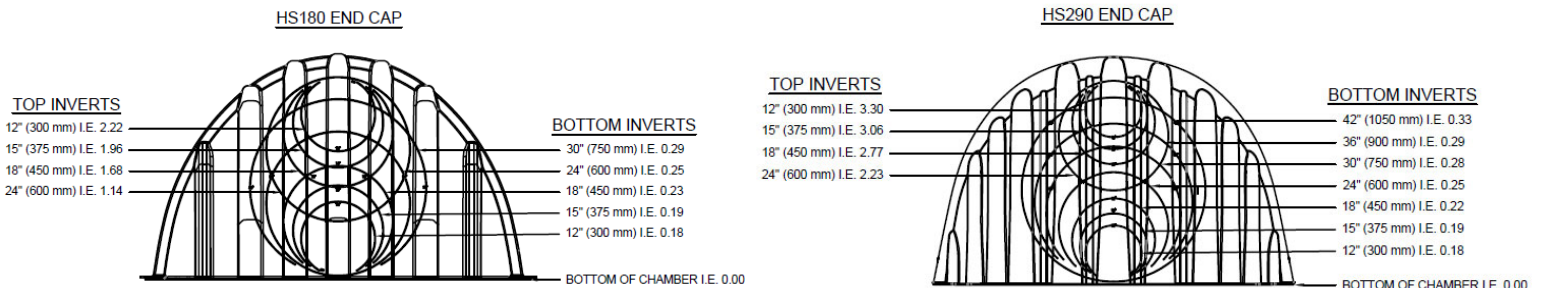

Figure 5 - End Cap Inverts

3.0 Structural Design

3.1 Design

Installation of HydroStor Chambers should be accomplished in accordance with the manufacturer's instructions. When installed correctly the HydroStor product line is designed to meet or exceed the American Association of State Highway and Transportation Officials (AASHTO) Load Resistance Factor Design (LRFD) design factors for dead loads (earth fill) and live loads (vehicular traffic). AASHTO vehicular live loads are designated as either a single axle 32 kip (142 kN) load or tandem 25 kip (111 kN) axle loads. The conservative design is based on additional factors for impact and multiple vehicles. The dead load applied is also subject to additional factors for safety.

Three dimensional models for the chambers were created. A Finite Element Analysis (FEA) was then utilized to determine required part thickness, weight, and shape to maximize the structural capacity of the product with an optimized profile. Maximum thrust, moment, local buckling, and deflection as well as other factors in both short term and long-term configurations were determined from the FEA.

The HydroStor chambers are designed for use in normal buried conditions and are not recommended for installation under structures, such as buildings, parking garages, or retaining walls as these could provide additional loading for which the chambers were not designed.

3.2 Testing

As part of the design and evaluation program, HydroStor chambers have been installed in field conditions to perform a variety of tests, including short term traffic loading, and continuous long term testing and monitoring. The full scale testing was designed to test the limits of the chambers and provide conclusive evidence that the product performs as designed and intended. Long term testing of HydroStor products is ongoing.

3.3 Molding

HydroStor chambers are constructed of polypropylene resin by injection molding. The entire system meets the design requirements of the AASHTO LRFD specifications as well as ASTM F2787 and ASTM F2418. The injection molding of the chambers provides a highly repeatable process for maintaining precise quality control of the parts as well as several other benefits including:

- Precise control of minimum wall thicknesses
- Precision fit for joints and end caps
- Engraved instructions for installation
- Handles on the Chambers
- Uniform Material Placement
- Consistent Structural Strength

3.4 Quality Control

HydroStor chambers are manufactured with stringent quality control measures in place. The incoming raw materials are routinely tested to ensure compliance with the minimum requirements of the resin for processing and end product performance. The chamber properties are measured at industry standard intervals, ensuring proper performance when installed in accordance with the manufacturer's instructions.

4.0 Subsurface Foundation Requirements

4.1 Foundation Requirements

The soil on which the HydroStor system is constructed must have adequate bearing capacity to support the system. The native soils must be able to maintain the bearing capacity when water has infiltrated into the subsurface system as well. If there is inadequate bearing capacity of the native soil, additional aggregate may be necessary in the foundation of the system. The foundation must be clean, washed, crushed, angular stone placed between the subgrade soil and the bottom of the chambers.

Increased dead load (fill) placed over top of the chamber system requires greater bearing capacity from the subgrade supporting the system. The strength of the foundation at the bottom of the chambers is determined by the bearing capacity of the subgrade soils and the depth of aggregate foundation stone that is placed. The deeper the stone placed in the foundation, the more the load is spread on the underlying subgrade allowing system installation in weaker native soils. Table 1 for the HS180 and HS290 provide the required foundation stone depth for required cover heights and subgrade bearing capacity combinations. Refer to Figure 6 for minimum requirements for foundation depths and chamber spacing.

If soils with a bearing capacity of less than 2.0 ksf (96 kPa) are encountered, a geotechnical engineer should evaluate the site conditions and make recommendations for installation of the system and required foundation preparation.

Table 1 – HS180 and HS290 Minimum Required Stone Foundation Depth, in (mm)

Cover Height ft (m)	Minimum Required Bearing Capacity of Native Soil Subgrade, ksf (kPa)																									
	4.4 (211)	4.3 (206)	4.2 (201)	4.1 (196)	4.0 (192)	3.9 (187)	3.8 (182)	3.7 (177)	3.6 (172)	3.5 (168)	3.4 (163)	3.3 (158)	3.2 (153)	3.1 (148)	3.0 (144)	2.9 (139)	2.8 (134)	2.7 (129)	2.6 (124)	2.5 (120)	2.4 (115)	2.3 (110)	2.2 (105)	2.1 (101)	2.0 (96)	
2 (0.61)	9 (229)	9 (229)	9 (229)	9 (229)	9 (229)	9 (229)	9 (229)	9 (229)	9 (229)	9 (229)	9 (229)	9 (229)	9 (229)	9 (229)	9 (229)	9 (229)	9 (229)	9 (229)	9 (229)	9 (229)	12 (305)	12 (305)	12 (305)	15 (381)	15 (381)	15 (381)
2.5 (0.76)	9 (229)	9 (229)	9 (229)	9 (229)	9 (229)	9 (229)	9 (229)	9 (229)	9 (229)	9 (229)	9 (229)	9 (229)	9 (229)	9 (229)	9 (229)	9 (229)	9 (229)	12 (305)	12 (305)	12 (305)	12 (305)	15 (381)	15 (381)	15 (381)	15 (381)	18 (457)
3 (0.91)	9 (229)	9 (229)	9 (229)	9 (229)	9 (229)	9 (229)	9 (229)	9 (229)	9 (229)	9 (229)	9 (229)	9 (229)	9 (229)	9 (229)	9 (229)	9 (229)	12 (305)	12 (305)	12 (305)	12 (305)	15 (381)	15 (381)	15 (381)	18 (457)	18 (457)	18 (457)
3.5 (1.07)	9 (229)	9 (229)	9 (229)	9 (229)	9 (229)	9 (229)	9 (229)	9 (229)	9 (229)	9 (229)	9 (229)	9 (229)	9 (229)	9 (229)	12 (305)	12 (305)	12 (305)	12 (305)	15 (381)	15 (381)	15 (381)	15 (381)	18 (457)	18 (457)	24 (610)	24 (610)
4 (1.22)	9 (229)	9 (229)	9 (229)	9 (229)	9 (229)	9 (229)	9 (229)	9 (229)	9 (229)	9 (229)	9 (229)	9 (229)	12 (305)	12 (305)	12 (305)	12 (305)	15 (381)	15 (381)	15 (381)	15 (381)	18 (457)	18 (457)	18 (457)	24 (610)	24 (610)	24 (610)
4.5 (1.37)	9 (229)	9 (229)	9 (229)	9 (229)	9 (229)	9 (229)	9 (229)	9 (229)	9 (229)	9 (229)	9 (229)	12 (305)	12 (305)	12 (305)	12 (305)	15 (381)	15 (381)	15 (381)	15 (381)	18 (457)	18 (457)	18 (457)	24 (610)	24 (610)	30 (762)	30 (762)
5 (1.52)	9 (229)	9 (229)	9 (229)	9 (229)	9 (229)	9 (229)	9 (229)	9 (229)	9 (229)	12 (305)	12 (305)	12 (305)	12 (305)	15 (381)	15 (381)	15 (381)	15 (381)	18 (457)	18 (457)	18 (457)	18 (457)	24 (610)	24 (610)	24 (610)	30 (762)	30 (762)
5.5 (1.68)	9 (229)	9 (229)	9 (229)	9 (229)	9 (229)	9 (229)	9 (229)	12 (305)	12 (305)	12 (305)	12 (305)	12 (305)	15 (381)	15 (381)	15 (381)	18 (457)	18 (457)	18 (457)	18 (457)	24 (610)	24 (610)	24 (610)	24 (610)	24 (610)	30 (762)	30 (762)
6 (1.83)	9 (229)	9 (229)	9 (229)	9 (229)	9 (229)	9 (229)	12 (305)	12 (305)	12 (305)	12 (305)	12 (305)	15 (381)	15 (381)	15 (381)	15 (381)	18 (457)	18 (457)	18 (457)	18 (457)	24 (610)	24 (610)	24 (610)	24 (610)	30 (762)	30 (762)	30 (762)
6.5 (1.98)	9 (229)	9 (229)	9 (229)	9 (229)	9 (229)	12 (305)	12 (305)	12 (305)	12 (305)	12 (305)	15 (381)	15 (381)	15 (381)	15 (381)	18 (457)	18 (457)	18 (457)	18 (457)	24 (610)	24 (610)	24 (610)	24 (610)	30 (762)	30 (762)	30 (762)	30 (762)
7 (2.13)	9 (229)	9 (229)	9 (229)	9 (229)	12 (305)	12 (305)	12 (305)	12 (305)	12 (305)	15 (381)	15 (381)	15 (381)	18 (457)	18 (457)	18 (457)	18 (457)	24 (610)	24 (610)	24 (610)	24 (610)	30 (762)	30 (762)	30 (762)	30 (762)	36 (914)	36 (914)
7.5 (2.29)	9 (229)	9 (229)	12 (305)	12 (305)	12 (305)	12 (305)	12 (305)	15 (381)	15 (381)	15 (381)	15 (381)	18 (457)	18 (457)	18 (457)	18 (457)	24 (610)	24 (610)	24 (610)	24 (610)	24 (610)	30 (762)	30 (762)	30 (762)	36 (914)	36 (914)	36 (914)
8 (2.44)	9 (229)	12 (305)	12 (305)	12 (305)	12 (305)	12 (305)	15 (381)	15 (381)	15 (381)	15 (381)	18 (457)	18 (457)	18 (457)	18 (457)	24 (610)	24 (610)	24 (610)	24 (610)	24 (610)	30 (762)	30 (762)	30 (762)	36 (914)	36 (914)	36 (914)	36 (914)

4.2 Chamber Row Spacing

The minimum required spacing between chamber rows is 8 inches (200 mm) for the HS180 and 8.5 inches (216 mm) for the HS290. This spacing is measured from the outside edges of the chamber feet. The spacing may be increased if necessary in order to mitigate the effects of weaker native subgrade soils or to reduce the amount of foundation stone required under the chambers.

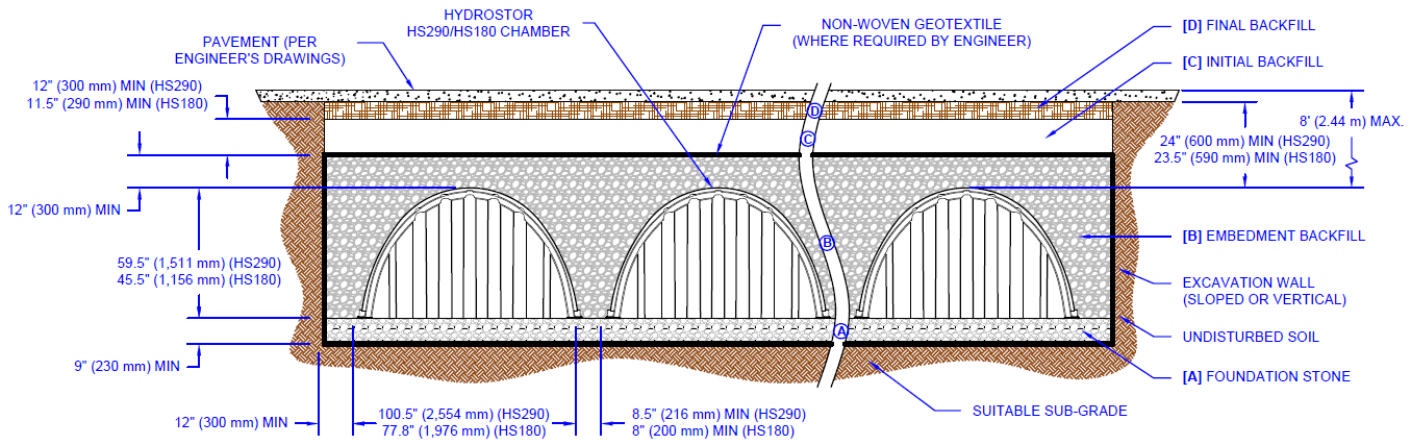

Figure 6 - HydroStor Chamber Cross Section

5.0 Installed Storage Volumes for HydroStor Chambers

5.1 Stage Storage Volumes

Tables 2, 3, 4, and 5 below provide the cumulative storage volumes for the HydroStor HS180 chamber and HS290 chambers and end caps, respectively. These tables can be used to calculate the stage-storage volumes for the retention or detention systems. If a thicker foundation layer is required, additional stone void storage would be possible. The storage in the installed system assumes a 40% stone porosity.

Table 2 – HS180 Incremental Storage Volume per Chamber

Calculations assume 12" (300 mm) of stone above chambers, 9" (230 mm) stone for foundation, 8" (200 mm) of stone between chambers and 40% stone porosity. Add 1.70 ft³ (0.048 m³) for each additional inch of stone foundation or stone cover.

Depth of water in the System in. (mm)		Cumulative Single Chamber Storage ft ³ (m ³)	Cumulative Storage for System ft ³ (m ³)	Depth of water in the System in. (mm)	Cumulative Single Chamber Storage ft ³ (m ³)	Cumulative Storage for System ft ³ (m ³)	
66 (1676)	↑ Stone Cover	113.56 (3.22)	179.59 (5.09)	33 (838)	76.75 (2.17)	101.78 (2.88)	
65 (1651)		113.56 (3.22)	177.9 (5.04)	32 (813)	73.98 (2.09)	98.43 (2.79)	
64 (1626)		113.56 (3.22)	176.21 (4.99)	31 (787)	71.16 (2.02)	95.05 (2.69)	
63 (1600)		113.56 (3.22)	174.52 (4.94)	30 (762)	68.29 (1.93)	91.64 (2.59)	
62 (1575)		113.56 (3.22)	172.83 (4.89)	29 (737)	65.37 (1.85)	88.2 (2.5)	
61 (1549)		113.56 (3.22)	171.14 (4.85)	28 (711)	62.41 (1.77)	84.73 (2.4)	
60 (1524)		113.56 (3.22)	169.45 (4.8)	27 (686)	59.41 (1.68)	81.24 (2.3)	
59 (1499)		↓	113.56 (3.22)	167.76 (4.75)	26 (660)	56.37 (1.6)	77.73 (2.2)
58 (1473)			113.56 (3.22)	166.07 (4.7)	25 (635)	53.3 (1.51)	74.2 (2.1)
57 (1448)			113.56 (3.22)	164.38 (4.65)	24 (610)	50.19 (1.42)	70.65 (2)
56 (1422)	113.56 (3.22)		162.69 (4.61)	23 (584)	47.05 (1.33)	67.08 (1.9)	
55 (1397)	113.56 (3.22)		161 (4.56)	22 (559)	43.88 (1.24)	63.49 (1.8)	
54 (1372)	113.56 (3.22)		159.31 (4.51)	21 (533)	40.68 (1.15)	59.88 (1.7)	
53 (1346)	113.38 (3.21)		157.51 (4.46)	20 (508)	37.45 (1.06)	56.25 (1.59)	
52 (1321)	113.07 (3.2)		155.63 (4.41)	19 (483)	34.19 (0.97)	52.61 (1.49)	
51 (1295)	112.63 (3.19)		153.68 (4.35)	18 (457)	30.9 (0.87)	48.95 (1.39)	
50 (1270)	112 (3.17)		151.62 (4.29)	17 (432)	27.58 (0.78)	45.27 (1.28)	
49 (1245)	110.98 (3.14)	149.32 (4.23)	16 (406)	24.23 (0.69)	41.57 (1.18)		
48 (1219)	109.71 (3.11)	146.87 (4.16)	15 (381)	20.85 (0.59)	37.86 (1.07)		
47 (1194)	108.25 (3.07)	144.3 (4.09)	14 (356)	17.45 (0.49)	34.13 (0.97)		
46 (1168)	106.63 (3.02)	141.64 (4.01)	13 (330)	14.02 (0.4)	30.38 (0.86)		
45 (1143)	104.87 (2.97)	138.9 (3.93)	12 (305)	10.56 (0.3)	26.61 (0.75)		
44 (1118)	102.99 (2.92)	136.09 (3.85)	11 (279)	7.07 (0.2)	22.83 (0.65)		
43 (1092)	101 (2.86)	133.21 (3.77)	10 (254)	3.55 (0.1)	19.03 (0.54)		
42 (1067)	98.92 (2.8)	130.27 (3.69)	9 (229)	↑ Stone Foundation	0 (0)	15.21 (0.43)	
41 (1041)	96.75 (2.74)	127.28 (3.6)	8 (203)		0 (0)	13.52 (0.38)	
40 (1016)	94.49 (2.68)	124.24 (3.52)	7 (178)		0 (0)	11.83 (0.33)	
39 (991)	92.16 (2.61)	121.15 (3.43)	6 (152)		0 (0)	10.14 (0.29)	
38 (965)	89.75 (2.54)	118.02 (3.34)	5 (127)		0 (0)	8.45 (0.24)	
37 (940)	87.27 (2.47)	114.85 (3.25)	4 (102)		0 (0)	6.76 (0.19)	
36 (914)	84.73 (2.4)	111.64 (3.16)	3 (76)		0 (0)	5.07 (0.14)	
35 (889)	82.13 (2.33)	108.39 (3.07)	2 (51)		0 (0)	3.38 (0.1)	
34 (864)	79.47 (2.25)	105.1 (2.98)	1 (25)		0 (0)	1.69 (0.05)	

Table 3 - HS290 Incremental Storage Volume per Chamber

Calculations assume 12" (300 mm) of stone above chambers, 9" (230 mm) stone for foundation, 8.5" (216 mm) of stone between chambers and 40% stone porosity. Add 1.22 ft³ (0.035 m³) for each additional inch of stone foundation or stone cover.

Depth of water in the System in. (mm)	Cumulative Single Chamber Storage ft ³ (m ³)	Cumulative Storage for System ft ³ (m ³)	Depth of water in the System in. (mm)	Cumulative Single Chamber Storage ft ³ (m ³)	Cumulative Storage for System ft ³ (m ³)
81 (2057)	109.67 (3.11)	164.03 (4.64)	40 (1016)	71.65 (2.03)	91.5 (2.59)
80 (2032)	109.67 (3.11)	162.82 (4.61)	39 (991)	69.57 (1.97)	89.04 (2.52)
79 (2007)	109.67 (3.11)	161.61 (4.58)	38 (965)	67.47 (1.91)	86.57 (2.45)
78 (1981)	109.67 (3.11)	160.4 (4.54)	37 (940)	65.35 (1.85)	84.08 (2.38)
77 (1956)	109.67 (3.11)	159.19 (4.51)	36 (914)	63.21 (1.79)	81.58 (2.31)
76 (1930)	Stone 109.67 (3.11)	157.98 (4.47)	35 (889)	61.05 (1.73)	79.07 (2.24)
75 (1905)	Cover 109.67 (3.11)	156.77 (4.44)	34 (864)	58.88 (1.67)	76.55 (2.17)
74 (1880)	109.67 (3.11)	155.56 (4.4)	33 (838)	56.69 (1.61)	74.02 (2.1)
73 (1854)	109.67 (3.11)	154.35 (4.37)	32 (813)	54.49 (1.54)	71.49 (2.02)
72 (1829)	109.67 (3.11)	153.14 (4.34)	31 (787)	52.28 (1.48)	68.95 (1.95)
71 (1803)	109.67 (3.11)	151.93 (4.3)	30 (762)	50.05 (1.42)	66.4 (1.88)
70 (1778)	109.67 (3.11)	150.72 (4.27)	29 (737)	47.81 (1.35)	63.84 (1.81)
69 (1753)	109.67 (3.11)	149.51 (4.23)	28 (711)	45.56 (1.29)	61.28 (1.74)
68 (1727)	109.67 (3.11)	148.3 (4.2)	27 (686)	43.3 (1.23)	58.71 (1.66)
67 (1702)	109.6 (3.1)	147.04 (4.16)	26 (660)	41.02 (1.16)	56.13 (1.59)
66 (1676)	109.42 (3.1)	145.72 (4.13)	25 (635)	38.73 (1.1)	53.54 (1.52)
65 (1651)	109.15 (3.09)	144.34 (4.09)	24 (610)	36.43 (1.03)	50.95 (1.44)
64 (1626)	108.8 (3.08)	142.92 (4.05)	23 (584)	34.12 (0.97)	48.35 (1.37)
63 (1600)	108.34 (3.07)	141.43 (4)	22 (559)	31.8 (0.9)	45.74 (1.3)
62 (1575)	107.62 (3.05)	139.78 (3.96)	21 (533)	29.47 (0.83)	43.13 (1.22)
61 (1549)	106.71 (3.02)	138.02 (3.91)	20 (508)	27.12 (0.77)	40.51 (1.15)
60 (1524)	105.67 (2.99)	136.18 (3.86)	19 (483)	24.76 (0.7)	37.88 (1.07)
59 (1499)	104.52 (2.96)	134.28 (3.8)	18 (457)	22.39 (0.63)	35.24 (1)
58 (1473)	103.28 (2.92)	132.32 (3.75)	17 (432)	20.01 (0.57)	32.6 (0.92)
57 (1448)	101.96 (2.89)	130.31 (3.69)	16 (406)	17.62 (0.5)	29.95 (0.85)
56 (1422)	100.56 (2.85)	128.26 (3.63)	15 (381)	15.22 (0.43)	27.3 (0.77)
55 (1397)	99.1 (2.81)	126.17 (3.57)	14 (356)	12.81 (0.36)	24.64 (0.7)
54 (1372)	97.57 (2.76)	124.04 (3.51)	13 (330)	10.39 (0.29)	21.97 (0.62)
53 (1346)	95.99 (2.72)	121.88 (3.45)	12 (305)	7.96 (0.23)	19.3 (0.55)
52 (1321)	94.36 (2.67)	119.69 (3.39)	11 (279)	5.51 (0.16)	16.62 (0.47)
51 (1295)	92.67 (2.62)	117.46 (3.33)	10 (254)	3.05 (0.09)	13.93 (0.39)
50 (1270)	90.94 (2.58)	115.21 (3.26)	9 (229)	0 (0)	10.89 (0.31)
49 (1245)	89.16 (2.52)	112.93 (3.2)	8 (203)	0 (0)	9.68 (0.27)
48 (1219)	87.35 (2.47)	110.63 (3.13)	7 (178)	0 (0)	8.47 (0.24)
47 (1194)	85.5 (2.42)	108.31 (3.07)	6 (152)	Stone 0 (0)	7.26 (0.21)
46 (1168)	83.61 (2.37)	105.96 (3)	5 (127)	Foundation 0 (0)	6.05 (0.17)
45 (1143)	81.69 (2.31)	103.59 (2.93)	4 (102)	0 (0)	4.84 (0.14)
44 (1118)	79.74 (2.26)	101.21 (2.87)	3 (76)	0 (0)	3.63 (0.1)
43 (1092)	77.76 (2.2)	98.81 (2.8)	2 (51)	0 (0)	2.42 (0.07)
42 (1067)	75.75 (2.15)	96.39 (2.73)	1 (25)	0 (0)	1.21 (0.03)
41 (1041)	73.71 (2.09)	93.95 (2.66)			

Table 4 - HS180 Incremental Storage Volume per End Cap

Calculations assume 12" (300 mm) of stone above chambers/end caps, 9" (230 mm) stone for foundation, 8" (200 mm) of stone between chambers/end caps, 6" (150 mm) of stone perimeter in front of the end caps and 40% stone porosity. Add 0.66 ft³ (0.019 m³) for each additional inch of stone foundation or stone cover.

Depth of water in the System in. (mm)	Cumulative Single Endcap Storage ft ³ (m ³)	Cumulative Storage for System ft ³ (m ³)	Depth of water in the System in. (mm)	Cumulative Single Endcap Storage ft ³ (m ³)	Cumulative Storage for System ft ³ (m ³)
66 (1676)	15.33 (0.43)	46 (1.3)	33 (838)	11.8 (0.33)	25.47 (0.72)
65 (1651)	15.33 (0.43)	45.44 (1.29)	32 (813)	11.45 (0.32)	24.7 (0.7)
64 (1626)	15.33 (0.43)	44.88 (1.27)	31 (787)	11.08 (0.31)	23.92 (0.68)
63 (1600)	15.33 (0.43)	44.32 (1.26)	30 (762)	10.71 (0.3)	23.14 (0.66)
62 (1575)	15.33 (0.43)	43.76 (1.24)	29 (737)	10.31 (0.29)	22.34 (0.63)
61 (1549)	Stone Cover	43.2 (1.22)	28 (711)	9.9 (0.28)	21.54 (0.61)
60 (1524)	15.33 (0.43)	42.64 (1.21)	27 (686)	9.48 (0.27)	20.73 (0.59)
59 (1499)	15.33 (0.43)	42.08 (1.19)	26 (660)	9.04 (0.26)	19.91 (0.56)
58 (1473)	15.33 (0.43)	41.52 (1.18)	25 (635)	8.59 (0.24)	19.08 (0.54)
57 (1448)	15.33 (0.43)	40.96 (1.16)	24 (610)	8.13 (0.23)	18.25 (0.52)
56 (1422)	15.33 (0.43)	40.4 (1.14)	23 (584)	7.66 (0.22)	17.41 (0.49)
55 (1397)	15.33 (0.43)	39.84 (1.13)	22 (559)	7.17 (0.2)	16.56 (0.47)
54 (1372)	15.33 (0.43)	39.28 (1.11)	21 (533)	6.67 (0.19)	15.7 (0.44)
53 (1346)	15.33 (0.43)	38.72 (1.1)	20 (508)	6.16 (0.17)	14.84 (0.42)
52 (1321)	15.32 (0.43)	38.16 (1.08)	19 (483)	5.64 (0.16)	13.97 (0.4)
51 (1295)	15.29 (0.43)	37.59 (1.06)	18 (457)	5.11 (0.14)	13.1 (0.37)
50 (1270)	15.24 (0.43)	37 (1.05)	17 (432)	4.57 (0.13)	12.22 (0.35)
49 (1245)	15.17 (0.43)	36.4 (1.03)	16 (406)	4.02 (0.11)	11.33 (0.32)
48 (1219)	15.09 (0.43)	35.8 (1.01)	15 (381)	3.46 (0.1)	10.44 (0.3)
47 (1194)	14.99 (0.42)	35.18 (1)	14 (356)	2.9 (0.08)	9.55 (0.27)
46 (1168)	14.87 (0.42)	34.55 (0.98)	13 (330)	2.33 (0.07)	8.65 (0.24)
45 (1143)	14.72 (0.42)	33.9 (0.96)	12 (305)	1.75 (0.05)	7.75 (0.22)
44 (1118)	14.56 (0.41)	33.25 (0.94)	11 (279)	1.17 (0.03)	6.85 (0.19)
43 (1092)	14.39 (0.41)	32.59 (0.92)	10 (254)	0.59 (0.02)	5.95 (0.17)
42 (1067)	14.2 (0.4)	31.92 (0.9)	9 (229)	0 (0)	5.04 (0.14)
41 (1041)	14 (0.4)	31.24 (0.88)	8 (203)	0 (0)	4.48 (0.13)
40 (1016)	13.78 (0.39)	30.55 (0.87)	7 (178)	0 (0)	3.92 (0.11)
39 (991)	13.55 (0.38)	29.86 (0.85)	6 (152)	Stone Foundation	0 (0)
38 (965)	13.3 (0.38)	29.15 (0.83)	5 (127)	0 (0)	2.8 (0.08)
37 (940)	13.03 (0.37)	28.43 (0.81)	4 (102)	0 (0)	2.24 (0.06)
36 (914)	12.75 (0.36)	27.71 (0.78)	3 (76)	0 (0)	1.68 (0.05)
35 (889)	12.45 (0.35)	26.97 (0.76)	2 (51)	0 (0)	1.12 (0.03)
34 (864)	12.13 (0.34)	26.22 (0.74)	1 (25)	0 (0)	0.56 (0.02)

Table 5 - HS290 Incremental Storage Volume per End Cap

Calculations assume 12" (300 mm) of stone above chambers/end caps, 9" (230 mm) stone for foundation, 8.5" (216 mm) of stone between chambers/end caps, 6" (150 mm) of stone perimeter in front of the end caps and 40% stone porosity. Add 1.06 ft³ (0.03 m³) for each additional inch of stone foundation or stone cover.

Depth of water in the System in. (mm)	Cumulative Single Endcap Storage ft ³ (m ³)	Cumulative Storage for System ft ³ (m ³)	Depth of water in the System in. (mm)	Cumulative Single Endcap Storage ft ³ (m ³)	Cumulative Storage for System ft ³ (m ³)
81 (2057)	39.6 (1.12)	109.51 (3.1)	40 (1016)	28.62 (0.81)	59.52 (1.69)
80 (2032)	39.6 (1.12)	108.45 (3.07)	39 (991)	27.87 (0.79)	58.01 (1.64)
79 (2007)	39.6 (1.12)	107.39 (3.04)	38 (965)	27.11 (0.77)	56.5 (1.6)
78 (1981)	39.6 (1.12)	106.33 (3.01)	37 (940)	26.33 (0.75)	54.97 (1.56)
77 (1956)	39.6 (1.12)	105.27 (2.98)	36 (914)	25.53 (0.72)	53.43 (1.51)
76 (1930)	Stone Cover	39.6 (1.12)	35 (889)	24.72 (0.7)	51.89 (1.47)
75 (1905)		39.6 (1.12)	103.15 (2.92)	34 (864)	23.89 (0.68)
74 (1880)	39.6 (1.12)	102.09 (2.89)	33 (838)	23.05 (0.65)	48.77 (1.38)
73 (1854)	39.6 (1.12)	101.03 (2.86)	32 (813)	22.2 (0.63)	47.2 (1.34)
72 (1829)	39.6 (1.12)	99.97 (2.83)	31 (787)	21.33 (0.6)	45.62 (1.29)
71 (1803)	39.6 (1.12)	98.91 (2.8)	30 (762)	20.45 (0.58)	44.03 (1.25)
70 (1778)	39.6 (1.12)	97.85 (2.77)	29 (737)	19.56 (0.55)	42.44 (1.2)
69 (1753)	39.6 (1.12)	96.79 (2.74)	28 (711)	18.66 (0.53)	40.84 (1.16)
68 (1727)	39.6 (1.12)	95.73 (2.71)	27 (686)	17.75 (0.5)	39.24 (1.11)
67 (1702)	39.58 (1.12)	94.66 (2.68)	26 (660)	16.83 (0.48)	37.63 (1.07)
66 (1676)	39.54 (1.12)	93.58 (2.65)	25 (635)	15.9 (0.45)	36.01 (1.02)
65 (1651)	39.47 (1.12)	92.48 (2.62)	24 (610)	14.96 (0.42)	34.39 (0.97)
64 (1626)	39.38 (1.12)	91.37 (2.59)	23 (584)	14.01 (0.4)	32.76 (0.93)
63 (1600)	39.27 (1.11)	90.25 (2.56)	22 (559)	13.05 (0.37)	31.13 (0.88)
62 (1575)	39.13 (1.11)	89.11 (2.52)	21 (533)	12.08 (0.34)	29.49 (0.84)
61 (1549)	38.95 (1.1)	87.94 (2.49)	20 (508)	11.1 (0.31)	27.84 (0.79)
60 (1524)	38.75 (1.1)	86.76 (2.46)	19 (483)	10.11 (0.29)	26.19 (0.74)
59 (1499)	38.51 (1.09)	85.56 (2.42)	18 (457)	9.12 (0.26)	24.54 (0.69)
58 (1473)	38.23 (1.08)	84.33 (2.39)	17 (432)	8.12 (0.23)	22.88 (0.65)
57 (1448)	37.91 (1.07)	83.08 (2.35)	16 (406)	7.11 (0.2)	21.22 (0.6)
56 (1422)	37.57 (1.06)	81.82 (2.32)	15 (381)	6.09 (0.17)	19.55 (0.55)
55 (1397)	37.2 (1.05)	80.54 (2.28)	14 (356)	5.07 (0.14)	17.88 (0.51)
54 (1372)	36.81 (1.04)	79.25 (2.24)	13 (330)	4.04 (0.11)	16.2 (0.46)
53 (1346)	36.39 (1.03)	77.94 (2.21)	12 (305)	3.01 (0.09)	14.52 (0.41)
52 (1321)	35.95 (1.02)	76.62 (2.17)	11 (279)	1.97 (0.06)	12.84 (0.36)
51 (1295)	35.47 (1)	75.27 (2.13)	10 (254)	0.92 (0.03)	11.15 (0.32)
50 (1270)	34.96 (0.99)	73.91 (2.09)	9 (229)	0 (0)	9.54 (0.27)
49 (1245)	34.43 (0.97)	72.53 (2.05)	8 (203)	0 (0)	8.48 (0.24)
48 (1219)	33.87 (0.96)	71.14 (2.01)	7 (178)	0 (0)	7.42 (0.21)
47 (1194)	33.29 (0.94)	69.73 (1.97)	6 (152)	Stone Foundation	0 (0)
46 (1168)	32.69 (0.93)	68.31 (1.93)	5 (127)		0 (0)
45 (1143)	32.07 (0.91)	66.88 (1.89)	4 (102)	0 (0)	4.24 (0.12)
44 (1118)	31.42 (0.89)	65.43 (1.85)	3 (76)	0 (0)	3.18 (0.09)
43 (1092)	30.75 (0.87)	63.97 (1.81)	2 (51)	0 (0)	2.12 (0.06)
42 (1067)	30.06 (0.85)	62.5 (1.77)	1 (25)	0 (0)	1.06 (0.03)
41 (1041)	29.35 (0.83)	61.02 (1.73)			

6.0 Required Materials for Installation

6.1 Chamber Row Separation

The HS180 is designed to have a minimum of 8 inches (200 mm) of spacing between each chamber with the footing of each chamber being parallel to the one next to it. The HS290 is designed to have a minimum spacing of 8.5 inches (216 mm) between the chambers. (Figure 7) Wider spacing is acceptable and will increase the storage with the additional stone voids as well as spreading the load on the native subgrade material. A brick or other spacer is recommended to maintain the required spacing between the chamber feet.

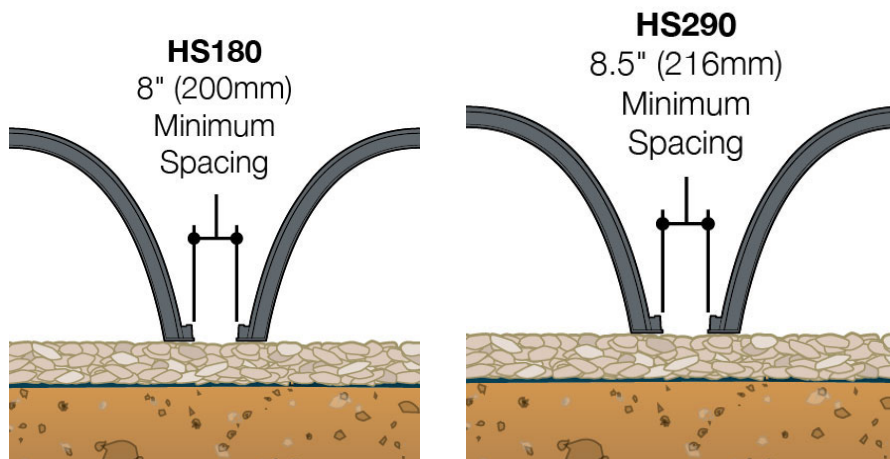

Figure 7 - Minimum Chamber Row Spacing

6.2 Stone Backfill

The acceptable stone materials for each of the backfill layers are shown in Table 6. The embedment stone which is used under, in between, and above the chambers must be washed, clean, crushed, and angular. The backfill placement and compaction recommendations are shown in Table 7. Figure 8 depicts a typical installation cross section for the HS180 and HS290 chambers. Table 6 and Figure 8 indicate the appropriate locations and types of backfill required for the installation of the chamber system. The material above the clean, crushed, angular backfill used to envelope the chambers (layer D) can be as specified by the engineer to provide adequate sub base for the overlying structures. Minimum and maximum fill requirements are also shown in Figure 8. The minimum cover for non-paved installations is 30" (750 mm) for HS180 and HS290 chambers.

Table 6 - Acceptable Backfill Requirements

Fill Material Location	Material Description	AASHTO M43 Designation
[D] Final Backfill- Fill material for Layer D starts at the top of the C layer to the bottom of the pavement or to the finished grade of an unpaved surface. The pavement subbase may be part of the final backfill.	Any backfill which provides adequate subgrade for the project per the engineer's plans. Plans shall indicate subgrade requirements.	N/A
[C] Initial Backfill- Material for layer C starts at the top of the embedment zone (layer B) and continues to 24" (600 mm) above the top of the chamber for the HS180 and HS290. The pavement subbase may be part of the initial backfill layer.	Well graded granular material, <35% fines.	AASHTO M45 A-1, A-2, A-3 or AASHTO M43 3, 357, 4, 467, 5, 56, 57, 6, 67, 68, 7, 78, 8, 89, 9,10
[B] Embedment Stone- Embedment stone will surround the chambers and extends from the top of the foundation stone (layer A) to the bottom of the fabric layer.	3/4" (19 mm) to 2" (51 mm) washed, crushed, angular stone.	AASHTO M43 3, 357, 4, 467, 5, 56, 57
[A] Foundation Stone- Foundation Stone extends from the sub grade to the foot of the chambers.	3/4" (19 mm) to 2" (51 mm) washed, crushed, angular stone.	AASHTO M43 3, 357, 4, 467, 5, 56, 57

Table 7 - Backfill Placement & Compaction Requirements

Fill Material Location	Placement Methods / Restrictions	HS180/HS290 Compaction Requirements
[D] Final Backfill	A variety of placement methods may be used. All construction loads must not exceed the limits in Table 4.	Subgrade will be placed and compacted to the requirements as shown on the site plans.
[C] Initial Backfill	Use of an excavator positioned off bed is recommended. Small excavators and small dozers may be allowed based on the information in Table 4.	Compaction will not begin until a minimum of 24" (600 mm) of material is placed over the chambers. Additional layers shall be compacted in 12" (300 mm) lifts to a minimum of 95% standard proctor density for well graded material.
[B] Embedment Stone	No equipment is allowed on bare chambers. Use excavator or stone conveyor positioned off bed to evenly place the backfill around and on top of all of the chambers.	No compaction required
[A] Foundation Stone	Placement with a variety of equipment is acceptable to provide a stable, level base.	Placed in 9" (230 mm) lifts and compacted with a vibratory roller.

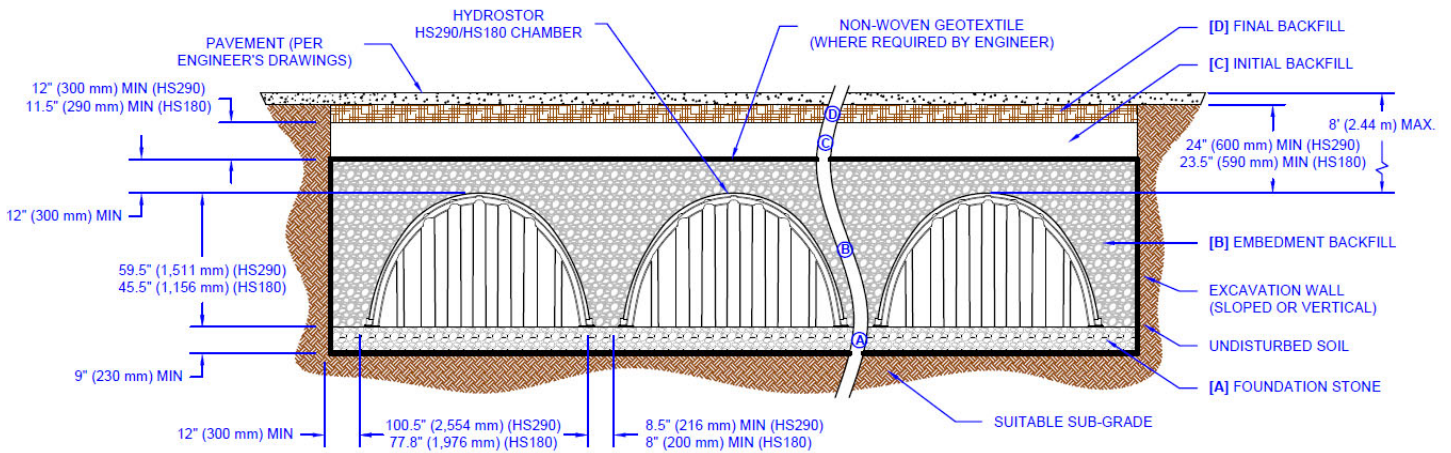

Figure 8 - Chamber Cross Section

6.3 Geotextile

The stone used in the foundation and backfill around the chambers is required to be open graded for water storage in the voids. Therefore it is necessary to protect the system from infiltration of the surrounding native soil. A 4 or 6oz/yd² (136 or 203 g/m²) non-woven geotextile is to be used around the entire chamber system to prevent soil infiltration into the crushed, angular stone around the chambers. The non-woven geotextile shall meet the requirements of an AASHTO M288 Class 2 separation fabric. The geotextile shall be overlapped a minimum of 24" (600 mm) as shown in Figure 9.

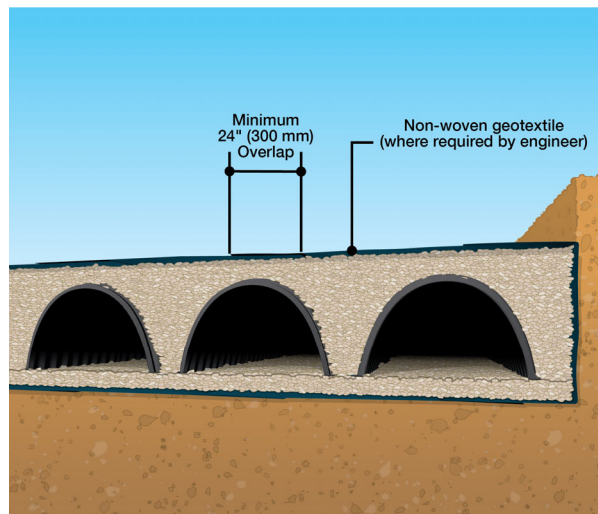

Figure 9 - AASHTO M288 Class 2 Separation Fabric

7.0 Stormwater Flow into Chambers

There are numerous ways of routing the stormwater from a developed site into the HydroStor chambers. Considering chambers have open bottoms, it is essential to utilize a pretreatment system to remove sediment and debris before the influent enters the chamber system. Below is some guidance on alternatives for the treatment of the inlet flow. Should more assistance be required, please contact your local Prinsco representative.

7.1 Retention/Detention and the Treatment Train

In addition to the retention / detention of stormwater, one of the functions of an underground system is the treatment of stormwater for water quality. When properly designed the HydroStor system can be combined with other stormwater treatment devices to provide a multi-tiered treatment approach for water quality, creating a very effective treatment train. The treatment train can consist of up to three levels of treatment for stormwater entering the HydroStor system including the following:

- Pre-Treatment Systems
- HydroStor Sediment Row
- Enhanced Stormwater Treatment

7.2 Pre-Treatment Systems

Depending on the location of the project, pre-treatment may be required prior to the stormwater entering the system. A pretreatment device can be used to reduce the pollutant load entering the system. By reducing the load entering the system, the service life of the system can be extended and sediment as well as other pollutants can be captured helping to meet local regulations.

The types of pretreatment systems can differ in method and effectiveness. A pretreatment device such as Prinsco's Stormwater Quality Unit (SWQU) treats the initial stormwater runoff before it reaches the chamber system. (Figure 10) Several standard units are available. Custom units, based on job specific requirements, can be manufactured. Refer to Prinsco's SWQU Product Detail & Bypass detail or contact your local Prinsco representative for more information.

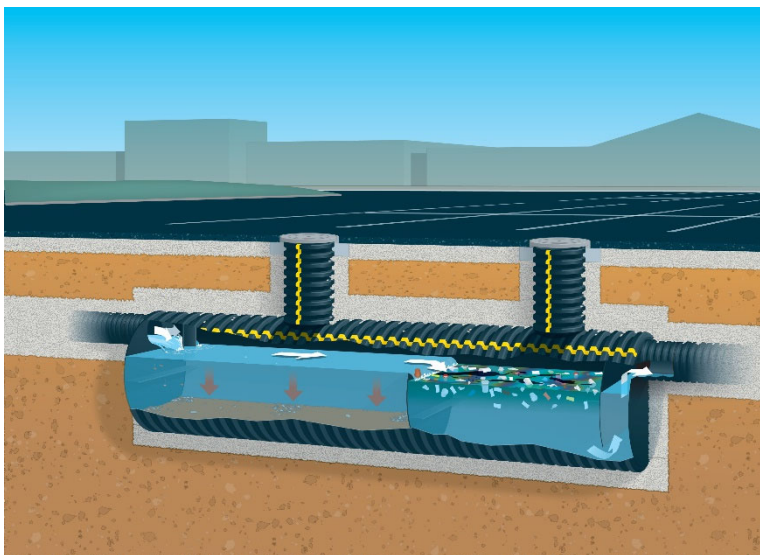

Figure 10 - Prinsco Stormwater Quality Unit (SWQU)

Other simple systems can potentially provide the level of treatment required based on the site's characteristics and the required treatment standards of the local regulations. Other treatment options include a manhole with a sump, gravity separators, hydrodynamic separators, and low impact development methods such as swales and grass strips.

The design engineer on the project is responsible for designing the appropriate water quality system based on the local regulations and requirements.

7.3 HydroStor Sediment Row

The HydroStor sediment row provides additional treatment for stormwater quality and enhances the removal of Total Suspended Solids. The sediment row consists of a series of chambers installed directly on top of two layers of woven geotextile fabric and is connected to a diversion manhole. The two layers of nonwoven geotextile directly beneath the chambers provide filtration of water leaving the row, capturing sediment and other pollutants within the row. Water in the sediment row has no outlet other than the bottom of the chamber and is forced through the filter fabric, providing the necessary filtration.

The sediment row is designed with a manhole and weir at the upstream end. The weir allows the initial runoff at the beginning of a storm, often referred to as the "first flush", to enter the sediment row for filtration. Once the weir height is reached, the remaining water flows through the manifold header and is distributed to the additional rows of the HydroStor chamber system. The manhole with the diversion weir is connected to the sediment row with a short length of HDPE pipe up to 24" (600 mm) for the HS180 and 42" (1050 mm) for the HS290. The downstream end of the sediment row has an end cap with no outlet.

Two layers of a woven geotextile, meeting the requirements of AASHTO M288 Class 1 stabilization fabric, are placed between bottom of the chambers and the stone foundation. This strong fabric allows water to pass through the chamber into the base stone yet keeps sediment and other pollutants within the sediment row.

In addition the fabric provides a strong base for cleaning the system using a JetVac type of technology. It is recommended that the two geotextile layers do not include any joints, overlaps or seams.

Inspection of the sediment row can be accomplished through the diversion manhole or through inspection ports which can be installed on the chambers. The maintenance of the system and cleanout is accomplished through the use of a JetVac process. The amount of sediment retained and the amount of water which is treated is based on the size of the project and the age of the system. Contact your local Prinsco representative for assistance on sizing of the sediment row. Further detail on the sediment row is shown in Figure 11.

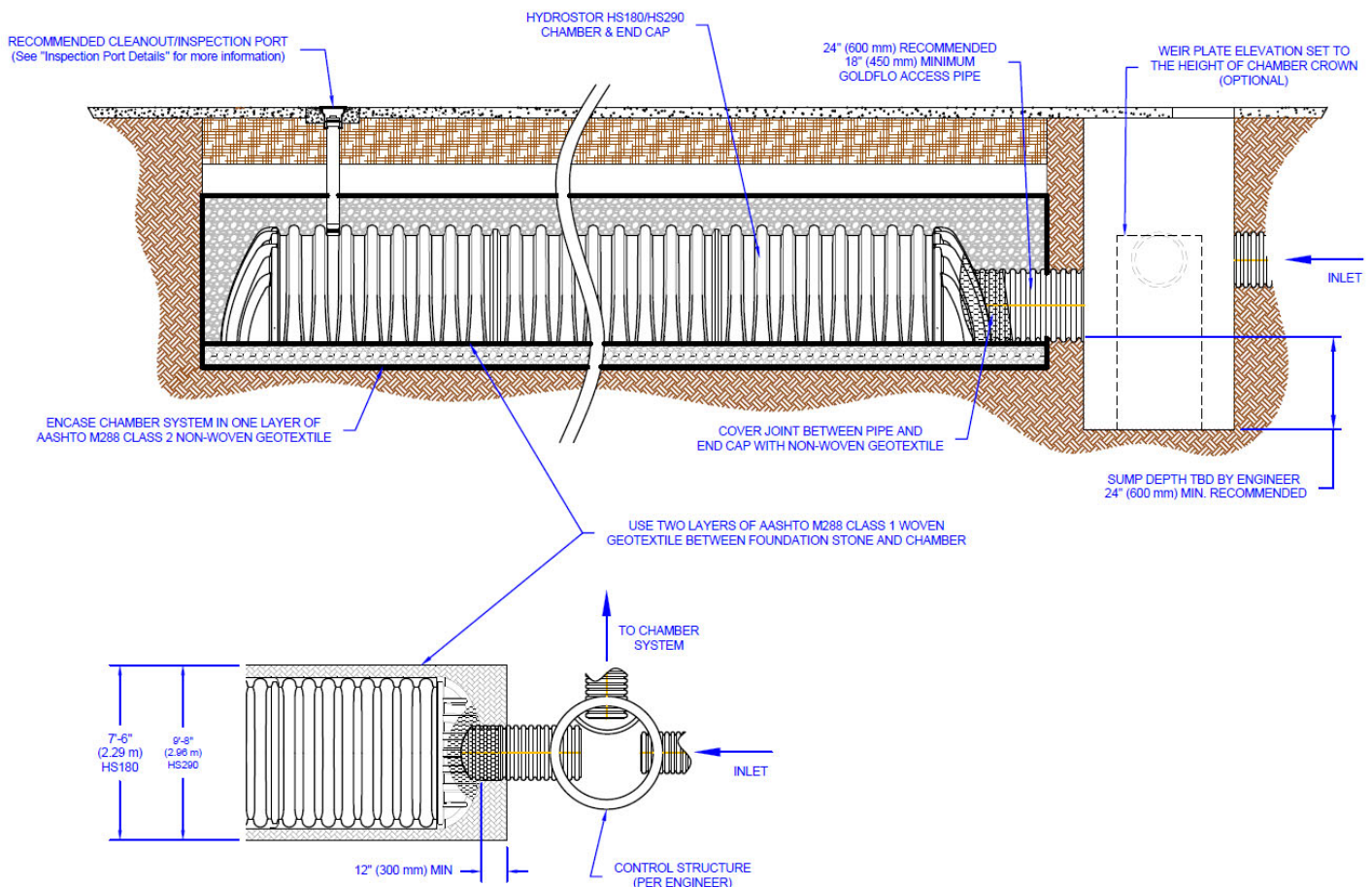

Figure 11 - Sediment Row

7.4 Enhanced Stormwater Treatment

In some regions, regulations may require further sediment removal beyond what a standard pretreatment device and sediment row are capable of. In these cases, the HydroStor system can easily be designed to accommodate further stormwater treatment either before or after the HydroStor chamber system. The location of the enhanced treatment is dependent on local regulations, the requirements of the site, and design engineer preferences. Contact your local Prinsco representative for further recommendations on enhanced treatment.

7.5 Treatment Train

The combination of all treatment devices is commonly referred to as the “treatment train”. Each device is intended to treat the stormwater to a higher level, removing smaller pollutants as the stormwater progresses through the system. The HydroStor chamber system provides the ability to not only store and treat water, but also work in combination with other devices to provide a comprehensive water quality solution.

7.6 Additional Inlet Options

Treatment of the stormwater is recommended prior to inletting into the chamber system. Depending on the type of pretreatment system, a diversion manhole may not be necessary and only the header system would be used to inlet the stormwater into the chamber bed. For inlet options using this alternative, see Figure 12. Contact your local Prinsco representative for a unique and cost-effective solution for your stormwater project.

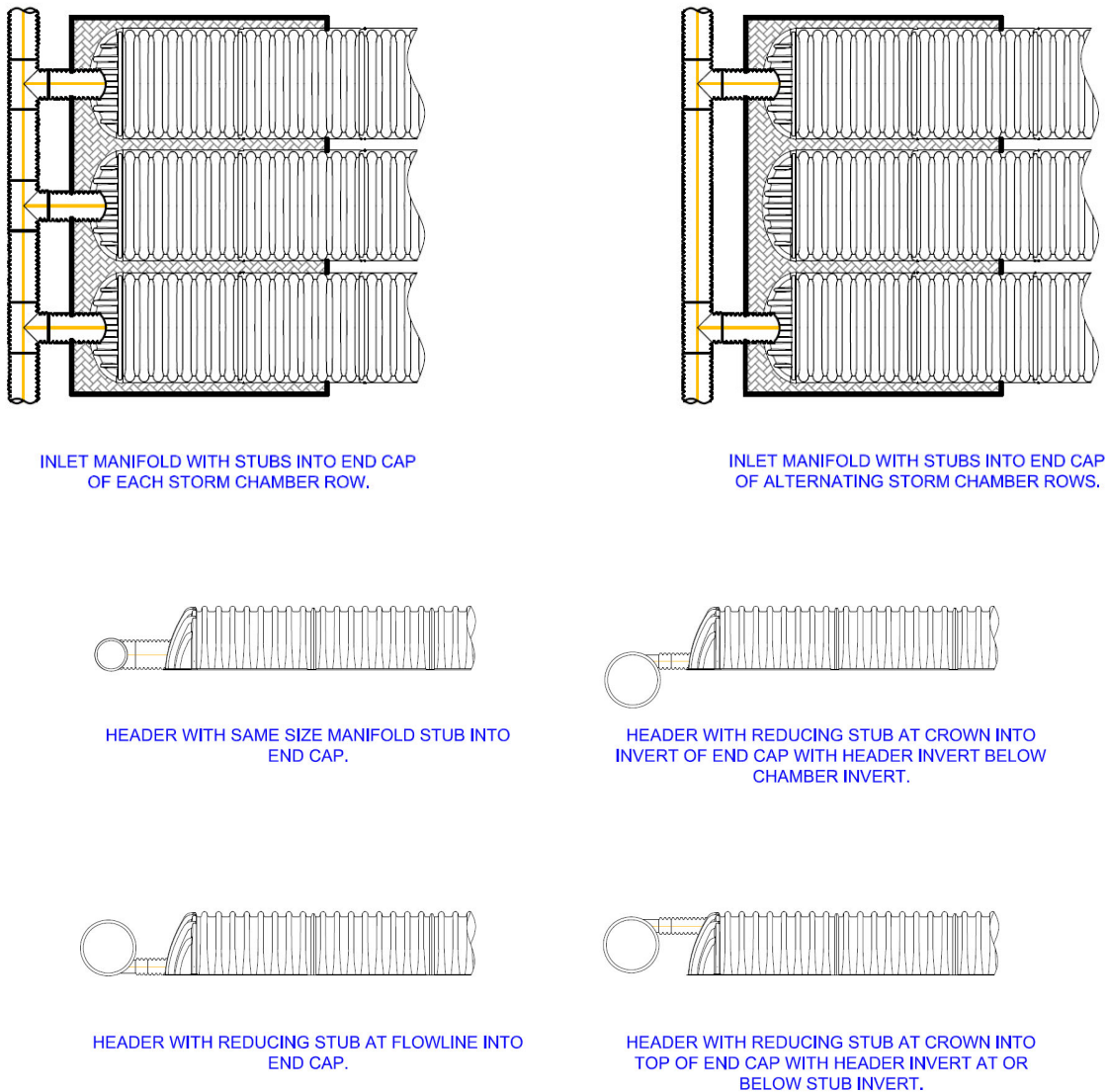

Figure 12 - Inlet Manifold Options

7.7 Perpendicular Inlets

In most installations, inlets to the chambers will be at the chamber row ends with a header system. However, an inlet perpendicular to the system may be desirable in some cases. If this is required, a chamber can be removed from a row and replaced with a tee connected to the inlet pipe. (Figure 13) The tee is then connected to the end caps of the chambers adjacent to the tee. A connection directly into the side of a chamber wall is not recommended.

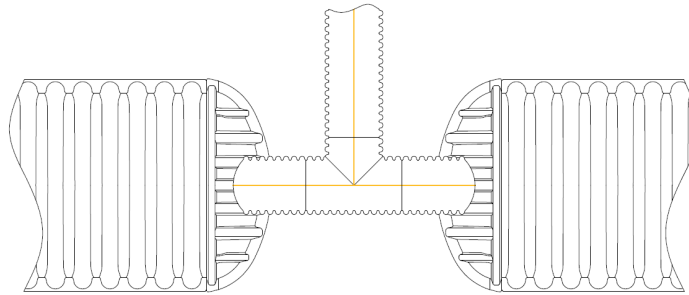

Figure 13 - Perpendicular Chamber Connection

7.8 Maximum Inlet Velocity

Water entering a chamber row too rapidly can potentially scour the foundation stone, leading to foundation issues in the chamber system. Prinsco recommends the use of a 15' (4.57 m) wide strip of an AASHTO M288 Class 1 non-woven stabilization geotextile under each chamber inlet row as a simple method to protect the stone from scour and structural loss. (Figure 14).

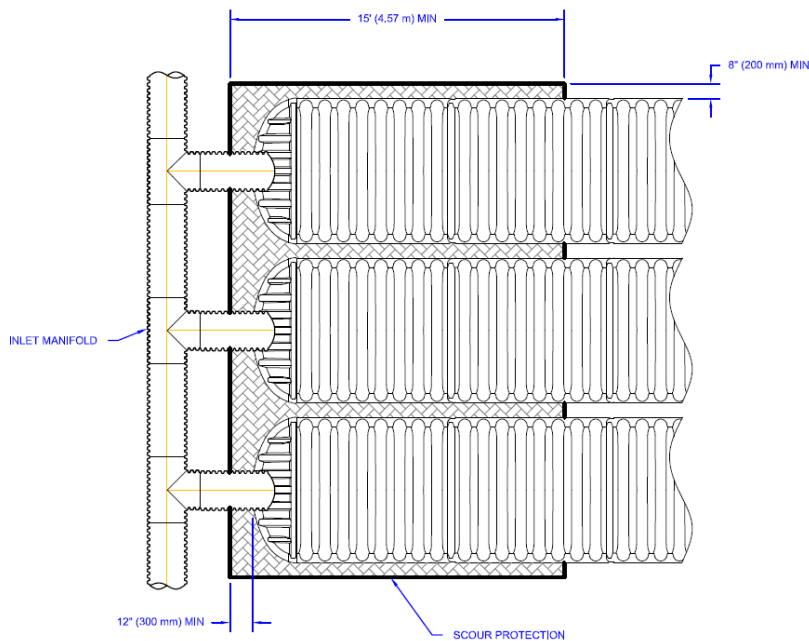

Figure 14 - Inlet Scour Protection

8.0 Outlet from HydroStor Chamber Systems

Most installations of chamber systems are used for detention and will therefore require some type of outlet structure. In detention design, the outlet structure is usually designed to match the pre-developed flow rates for each storm as closely as possible.

Since the chamber system utilizes the stone surrounding it for additional storage, an underdrain system may be necessary to completely drain the system. The underdrain must be located in or under the foundation stone, preferably in a sump area to completely drain the system. If a sump is used, it is usually unnecessary to slope the base to provide drainage. The underdrain should not be installed under the chambers. Figure 15 depicts an optional underdrain outlet configuration with minimum recommended dimensions.

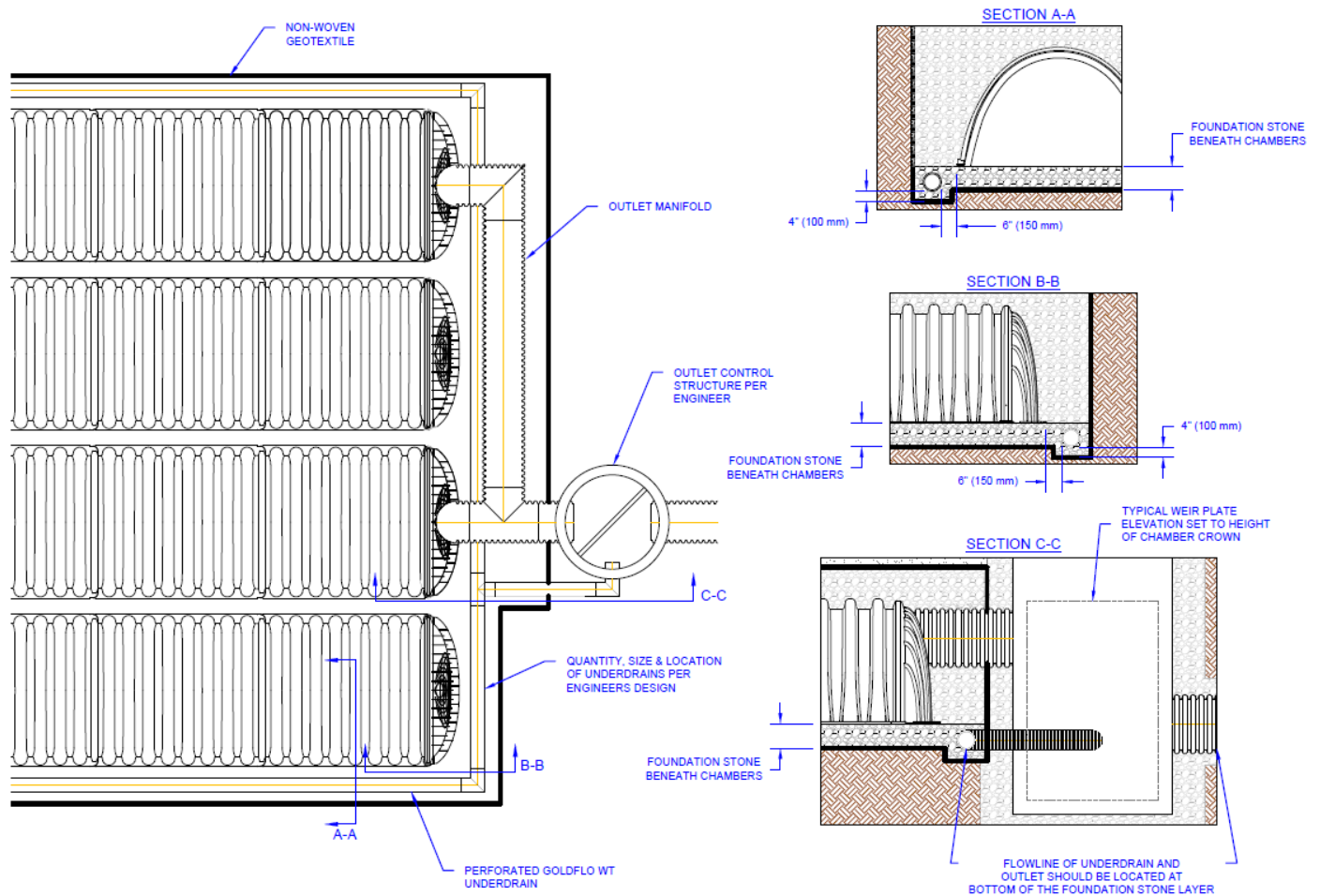

Figure 15 - Optional Underdrain Outlet

One of the benefits of an open bottom chamber system is its ability to infiltrate stormwater back into the ground, providing a situation closer to the pre-developed conditions. A combined outlet approach can help minimize the storage volume needed by providing the ability to infiltrate a portion of the stormwater runoff, while releasing excess flow during large storm events through the drainage system. This can be accomplished by providing an outlet structure or pipe with a higher invert elevation within the HydroStor system. The excess volume is released through an outlet structure while the remaining storm water runoff infiltrates into the ground.

Outlet pipes or structures should be placed along the perimeter of the HydroStor system as shown in Figure 16. An outlet pipe manifold should be connected to the downstream end cap(s) at the designed invert. The sediment row should not be connected to an outlet pipe as that will allow sediment to escape from the system. If one outlet is insufficient for the system, multiple outlets may be installed. It is the design engineers' responsibility to properly design a system that meets the hydraulic and hydrologic requirements of the site to be developed, while meeting all applicable laws.

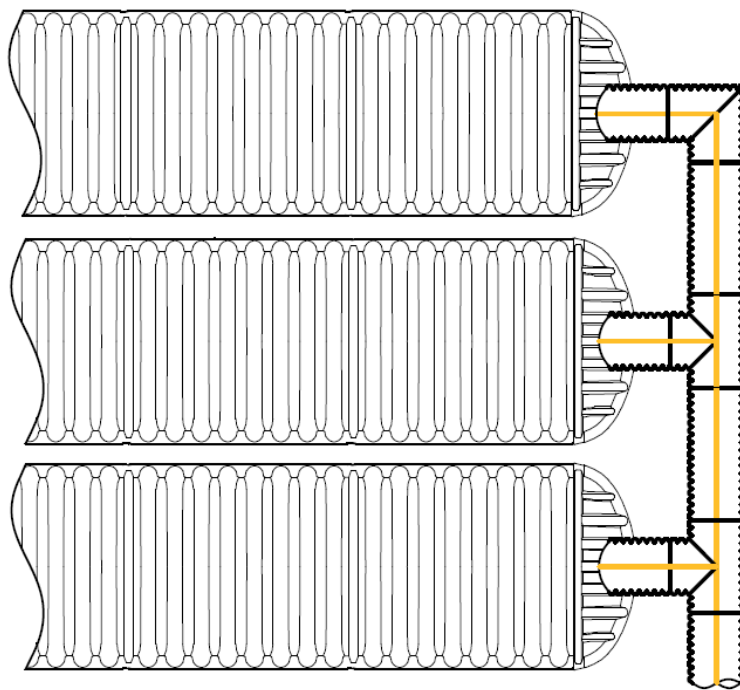

Figure 16 - Outlet Manifold Configuration

9.0 Other Considerations

9.1 Impermeable Liners

In addition to functioning as an open bottom detention system or infiltrating retention system (into the underlying soil), the HydroStor chamber system can be designed as a watertight system, preventing stormwater from infiltrating into the subsurface. A watertight option may be desirable in conditions where the groundwater is contaminated or underlying conditions could be impacted by excess water infiltration. When it is not desirable for the water to infiltrate into the underlying soil, a thermoplastic liner may be used to provide an impermeable barrier and prevent infiltration into the subsurface. Thermoplastic liner options include:

- Polyvinyl Chloride (PVC), 30 Mil PVC
- Linear Low Density Polyethylene (LLDPE), 30 Mil LLDPE
- Reinforced Polypropylene (RPP), EPDM, and XR-5

Liners installed with HydroStor chamber system require proper installation in accordance with the manufacturer’s installation instructions. It is recommended that a 6 oz/yd² non-woven geotextile be placed on both sides of the thermoplastic liner to protect the liner from puncture or protrusions. Refer to Figure 17 below or contact your local Prinsco representative for more information regarding the design and installation of liner systems for storm water applications with HydroStor chamber systems.

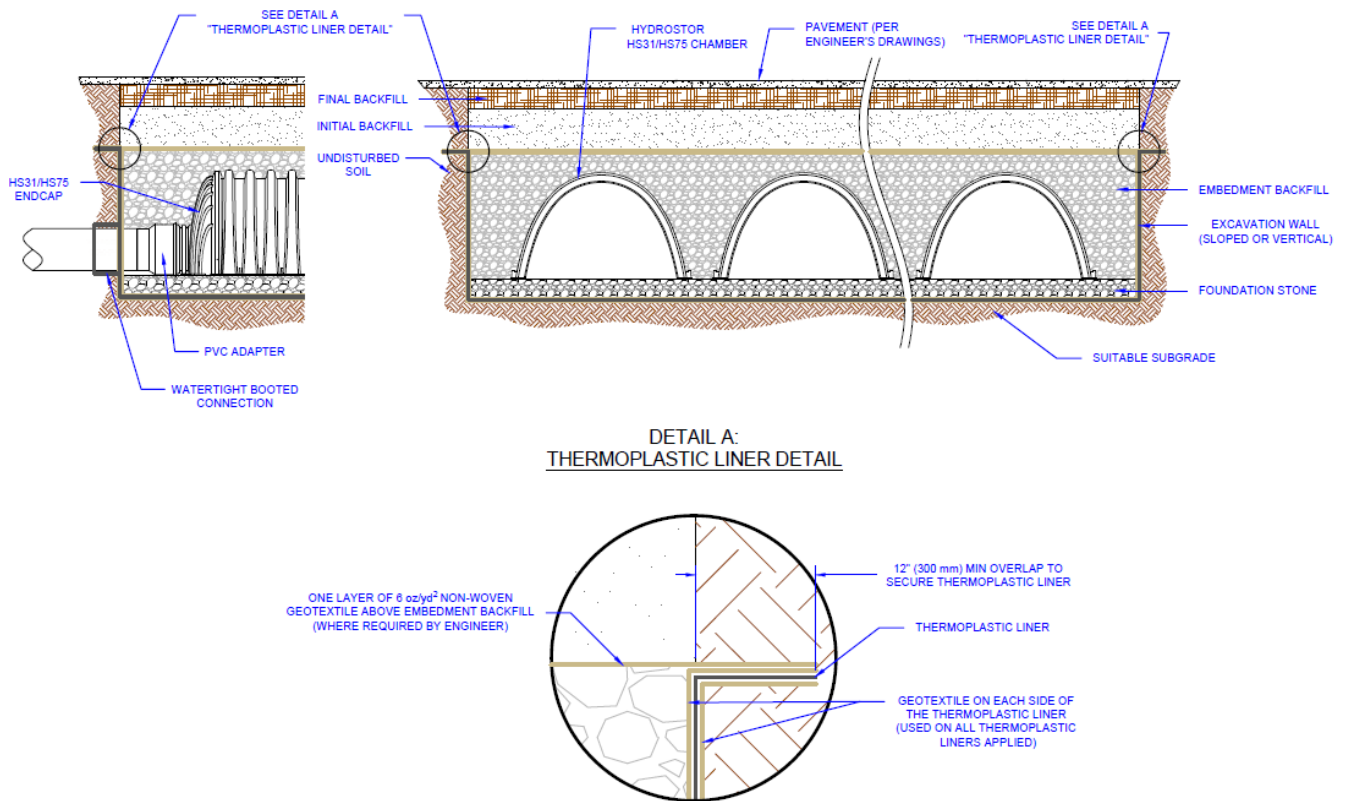

Figure 17 - Impermeable Liner Cross Section

10.0 System Sizing

To assist in the design of the HydroStor chamber systems, a Chamber System Design Aid (XLS) calculator is available on Prinsco's website, www.prinsco.com. This calculator enables the user to input the design criteria and estimates the quantities needed for the system. Contact your local Prinsco representative for further information on use of the calculator.

10.1 Sizing a HydroStor Chamber System

The design of a detention or retention system is the responsibility of the design engineer for the site being developed. The following steps provide guidance and information necessary for the design of the HydroStor system. All calculations and design functions must be accomplished and approved by the design engineer. If you need technical assistance with the layout or design of the HydroStor system contact your local Prinsco representative.

STEP 1: Determine the amount of storage required for the system.

The determination for the volume of water to be stored is the sole responsibility of the design engineer based on local codes, regulations, and design practice.

STEP 2: Determine the number of chambers required.

To determine the number of chambers needed, divide the amount of storage required by the volume of the chamber selected. The volume of storage available per chamber is provided in Table 8.

Table 8 - Chamber & Stone Storage Volumes

Unit & Stone Storage Volume, ft ³ (m ³)				
Stone Foundation Depths, in (mm)	HS180 Chamber	HS180 Endcap	HS290 Chamber	HS290 Endcap
Bare Unit	113.6 (3.22)	15.33 (0.43)	109.6 (3.1)	39.7 (1.12)
9 (230)	180 (5.1)	46 (1.3)	163.9 (4.64)	109.51 (3.1)
12 (300)	185.1 (5.24)	48 (1.36)	167.6 (4.75)	112.7 (3.19)
15 (380)	190.2 (5.39)	50 (1.42)	171.3 (4.85)	115.9 (3.28)
18 (460)	195.3 (5.53)	52 (1.47)	175 (4.96)	119.1 (3.37)

STEP 3: Determine the required foundation size for the chambers.

To determine the size of the bed, multiply the number of chambers required by the foundation area per chamber.

HS180 Chamber Foundation Area = 50.8 ft² (4.72 m²)

HS180 End Cap Foundation Area = 19.8 ft² (1.84 m²)

HS290 Chamber Foundation Area = 36.6 ft² (3.40 m²)

HS290 End Cap Foundation Area = 31.9 ft² (2.96 m²)

In addition to the foundation area calculated, an additional 1 foot (300 mm) should be added around the chamber foundation to provide for working room and backfill of the chambers.

STEP 4: Determine the amount of aggregate required.

To determine the amount of aggregate required, multiply the number of chambers by the selected foundation depth as shown in Table 9 below.

Table 9 - Stone Required per Chamber / End Cap

Stone Foundation Depths, in (mm)	Stone Volume yd ³ , US tons (m ³ , metric tons)			
	HS180 Chamber	HS180 Endcap	HS290 Chamber	HS290 Endcap
9 (230)	6.22, 8.4 (4.76, 7.62)	3.49, 4.71 (2.67, 4.27)	5.02, 6.78 (3.84, 6.15)	6.45, 8.71 (4.93, 7.9)
12 (300)	6.69, 9.03 (5.12, 8.19)	3.67, 4.96 (2.81, 4.5)	5.36, 7.24 (4.1, 6.57)	6.75, 9.11 (5.16, 8.26)
15 (380)	7.16, 9.67 (5.48, 8.77)	3.86, 5.21 (2.95, 4.73)	5.7, 7.7 (4.36, 6.99)	7.04, 9.51 (5.39, 8.63)
18 (460)	7.63, 10.3 (5.84, 9.34)	4.04, 5.46 (3.09, 4.95)	6.04, 8.15 (4.62, 7.39)	7.34, 9.91 (5.61, 8.99)

STEP 5: Calculate the volume of the excavation required.

The volume of excavation required per chamber is shown in Table 10 and 11 below. In addition, 1 foot (300 mm) of excavation is required around the perimeter and must be included.

Table 10 – HS180 Volume of Excavation Required per Chamber

Stone Foundation Depths, in (mm)	Volume of Excavation yd ³ (m ³)	
	Chamber	Endcap
9 (230)	12.23 (9.35)	4.76 (3.64)
12 (300)	12.7 (9.71)	4.94 (3.78)
15 (380)	13.17 (10.07)	5.13 (3.92)
18 (460)	13.64 (10.43)	5.31 (4.06)

**Assumes 8" (200 mm) of separation between chamber rows, 6" (150 mm) of perimeter in front of end caps and 23.5" (590 mm) of cover minimum. If the depth of cover exceeds 23.5" (590 mm), the volume should be increased 1.88cy (1.44 m³) per chamber and 0.73cy (0.56 m³) per end cap for each additional foot (300 m) of depth.*

Table 11 – HS290 Volume of Excavation Required per Chamber / End Cap

Stone Foundation Depths, in (mm)	Volume of Excavation yd ³ (m ³)	
	Chamber	Endcap
9 (230)	10.44 (7.98)	9.1 (6.96)
12 (300)	10.78 (8.24)	9.4 (7.19)
15 (380)	11.11 (8.5)	9.69 (7.41)
18 (460)	11.45 (8.76)	9.99 (7.64)

**Assumes 8.5" (200 mm) of separation between chamber rows, 6" (150 mm) of perimeter in front of end caps and 24" (600 mm) of cover minimum. If the depth of cover exceeds 24" (600 mm), the volume should be increased 1.35cy (1.04 m³) per chamber and 1.18cy (0.90 m³) per end cap for each additional foot (300 m) of depth.*

STEP 6: Calculate the amount of nonwoven geotextile required.

The bottom, sides, and top of the embedment stone must be covered with a 4 or 6 oz/yd² (136 or 203 g/m²) non-woven geotextile. Allowances should be made to include the 2 feet (600 mm) overlap required at all geotextile joints.

STEP 7: Determine the number of End Caps needed

Each row of chambers requires 2 end caps. If a row is terminated and restarted, two additional end caps will be required on that row.

11.0 Structural Cross Sections and Specifications

Figure 18 – HS180 Structural Cross Section Detail

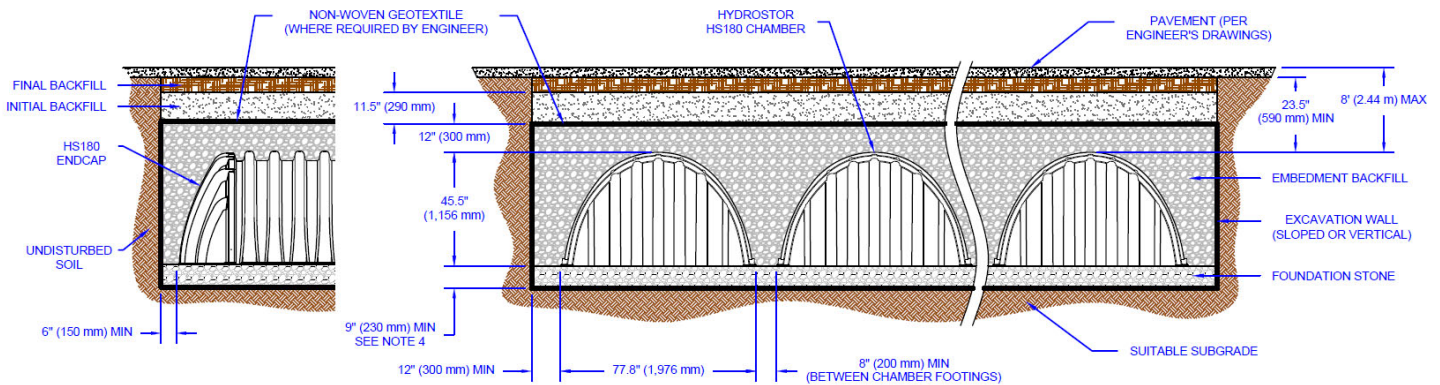

HS180 STORMWATER CHAMBER SPECIFICATIONS

1. CHAMBERS SHALL BE HYDROSTOR HS180 OR APPROVED EQUIVALENT.
2. CHAMBERS SHALL BE MADE FROM VIRGIN, IMPACT-MODIFIED POLYPROPYLENE COPOLYMERS.
3. CHAMBER ROWS SHALL PROVIDE CONTINUOUS, UNOBSTRUCTED INTERNAL SPACE WITH NO INTERNAL SUPPORT PANELS THAT WOULD IMPEDE FLOW OR LIMIT ACCESS FOR INSPECTION.
4. THE STRUCTURAL DESIGN OF THE CHAMBERS, THE STRUCTURAL BACKFILL, AND THE INSTALLATION REQUIREMENTS SHALL ENSURE THAT THE LOAD FACTORS SPECIFIED IN THE AASHTO LRFD BRIDGE DESIGN SPECIFICATIONS, SECTION 12.12, ARE MET FOR: 1) LONG-DURATION DEAD LOADS AND 2) SHORT-DURATION LIVE LOADS, BASED ON THE AASHTO DESIGN TRUCK WITH CONSIDERATION FOR IMPACT AND MULTIPLE VEHICLE PRESENCES.
5. CHAMBERS SHALL MEET THE REQUIREMENTS OF ASTM F2418-12, "STANDARD SPECIFICATION FOR POLYPROPYLENE (PP) CORRUGATED WALL STORMWATER COLLECTION CHAMBERS."
6. ONLY CHAMBERS THAT ARE APPROVED BY THE SITE DESIGN ENGINEER WILL BE ALLOWED. THE CHAMBER MANUFACTURER SHALL SUBMIT THE FOLLOWING UPON REQUEST TO THE SITE DESIGN ENGINEER FOR APPROVAL BEFORE DELIVERING CHAMBERS TO THE PROJECT SITE:
 - A. A STRUCTURAL EVALUATION SEALED BY A REGISTERED PROFESSIONAL ENGINEER THAT DEMONSTRATES THAT THE SAFETY FACTORS ARE GREATER THAN OR EQUAL TO 1.95 FOR DEAD LOAD AND 1.75 FOR LIVE LOAD, THE MINIMUM REQUIRED BY ASTM F2787 AND BY AASHTO FOR THERMOPLASTIC PIPE.
 - B. A STRUCTURAL EVALUATION SEAL BY A REGISTERED PROFESSIONAL ENGINEER THAT DEMONSTRATES THAT THE LOAD FACTORS SPECIFIED IN THE AASHTO LRFD BRIDGE DESIGN SPECIFICATIONS, SECTION 12.12, ARE MET. THE 50 YEAR CREEP MODULUS DATA SPECIFIED IN ASTM F2418 MUST BE USED AS PART OF THE AASHTO STRUCTURAL EVALUATION TO CERTIFY LONG-TERM PERFORMANCE.
 - C. STRUCTURAL CROSS SECTION DETAIL ON WHICH THE STRUCTURAL EVALUATION IS BASED.
7. CHAMBERS SHALL BE PRODUCED AT AN ISO 9001 CERTIFIED MANUFACTURING FACILITY.
8. PRIOR TO BEGINNING INSTALLATION OF HYDROSTOR STORMWATER CHAMBERS, A PRECONSTRUCTION MEETING SHALL BE HELD WITH A PRINSCO REPRESENTATIVE AND THE INSTALLERS.
9. HYDROSTOR STORMWATER CHAMBERS SHALL BE INSTALLED IN ACCORDANCE WITH THE PRINSCO "HYDROSTOR CONSTRUCTION GUIDE."
10. HYDROSTOR STORMWATER CHAMBERS SHALL NOT BE INSTALLED ON WET OR UNSTABLE FOUNDATION OR SUBGRADE. FOUNDATION STONE MUST BE LEVEL AND COMPACTED.
11. PRINSCO RECOMMENDS PRETREATMENT OF STORMWATER RUNOFF USING A PRINSCO STORMWATER QUALITY UNIT AND/OR A SEDIMENT ROW.
12. MAINTAIN MINIMUM SPACING OF 8" (SPECIFICALLY HS180) BETWEEN CHAMBERS.
13. CONSTRUCTION EQUIPMENT SHALL NOT BE SITUATED ATOP THE CHAMBERS UNTIL SUFFICIENT COVER HAS BEEN ACHIEVED. DUMP TRUCKS, RUBBER TIRE LOADERS, EXCAVATORS, WHEEL OR ROLLER LOADS ARE NOT ALLOWED UNTIL PROPER FILL HEIGHTS HAVE BEEN ACHIEVED. REFER TO PRINSCO "HYDROSTOR CONSTRUCTION GUIDE" FOR SPECIFIC LOADING CRITERIA.
14. EMBEDMENT BACKFILL MUST BE PLACED USING THE FOLLOWING METHODS ONLY:
 - A. BACKFILL WITH AN EXCAVATOR LOCATED OUTSIDE THE EXCAVATION
 - B. BACKFILL WITH A STONE SHOOTER LOCATED OUTSIDE THE EXCAVATION
 - C. BACKFILL AS ROWS ARE BUILT WITH AN EXCAVATOR ON THE SUBGRADE OR FOUNDATION STONE
15. EMBEDMENT BACKFILL SHALL NOT BE PLACED USING THE "DUMP AND PUSH" METHOD. THIS MAY CAUSE DAMAGE TO THE CHAMBERS, WILL RESULT IN IMPROPER INSTALLATION AND WILL VOID THE PRINSCO STANDARD WARRANTY.
16. ONCE SUFFICIENT COVER IS ACHIEVED (12" FOR HS180), GRADING MAY COMMENCE WITH A SMALL DOZER OR SKID LOADER (LESS THAN 4.5 PSI GROUND PRESSURE). EQUIPMENT SHALL ALWAYS TRAVEL PARALLEL TO CHAMBER ROWS. SEE PRINSCO "HYDROSTOR CONSTRUCTION GUIDE" FOR SPECIFIC LOADING CRITERIA.

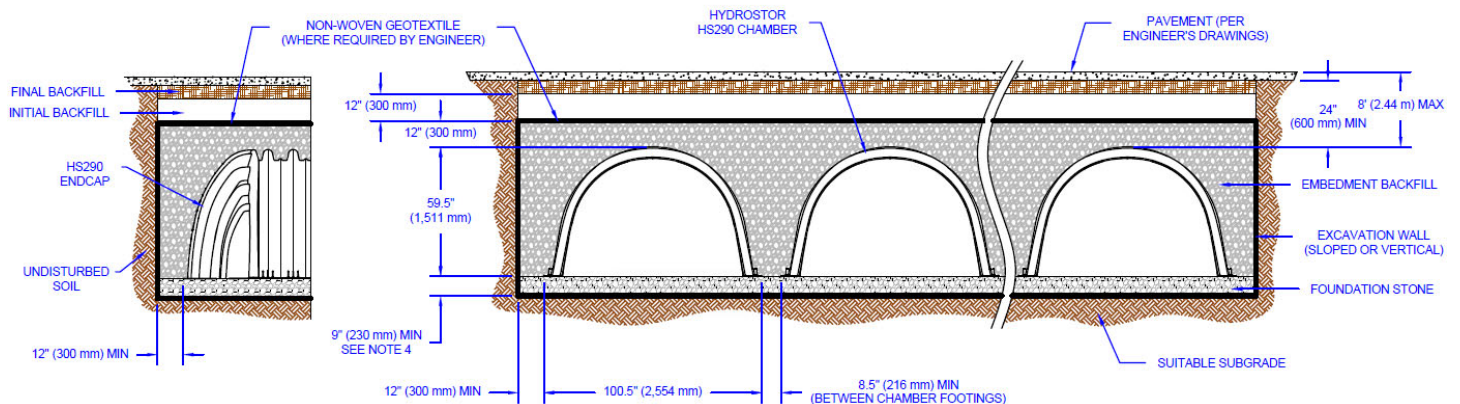
Figure 18 – HS180 Structural Cross Section Detail

HS290 STORMWATER CHAMBER SPECIFICATIONS

17. CHAMBERS SHALL BE HYDROSTOR HS290 OR APPROVED EQUIVALENT.
18. CHAMBERS SHALL BE MADE FROM VIRGIN, IMPACT-MODIFIED POLYPROPYLENE COPOLYMERS.
19. CHAMBER ROWS SHALL PROVIDE CONTINUOUS, UNOBSTRUCTED INTERNAL SPACE WITH NO INTERNAL SUPPORT PANELS THAT WOULD IMPEDE FLOW OR LIMIT ACCESS FOR INSPECTION.
20. THE STRUCTURAL DESIGN OF THE CHAMBERS, THE STRUCTURAL BACKFILL, AND THE INSTALLATION REQUIREMENTS SHALL ENSURE THAT THE LOAD FACTORS SPECIFIED IN THE AASHTO LRFD BRIDGE DESIGN SPECIFICATIONS, SECTION 12.12, ARE MET FOR: 1) LONG-DURATION DEAD LOADS AND 2) SHORT-DURATION LIVE LOADS, BASED ON THE AASHTO DESIGN TRUCK WITH CONSIDERATION FOR IMPACT AND MULTIPLE VEHICLE PRESENCES.
21. CHAMBERS SHALL MEET THE REQUIREMENTS OF ASTM F2418-12, "STANDARD SPECIFICATION FOR POLYPROPYLENE (PP) CORRUGATED WALL STORMWATER COLLECTION CHAMBERS."
22. ONLY CHAMBERS THAT ARE APPROVED BY THE SITE DESIGN ENGINEER WILL BE ALLOWED. THE CHAMBER MANUFACTURER SHALL SUBMIT THE FOLLOWING UPON REQUEST TO THE SITE DESIGN ENGINEER FOR APPROVAL BEFORE DELIVERING CHAMBERS TO THE PROJECT SITE:
 - A. A STRUCTURAL EVALUATION SEALED BY A REGISTERED PROFESSIONAL ENGINEER THAT DEMONSTRATES THAT THE SAFETY FACTORS ARE GREATER THAN OR EQUAL TO 1.95 FOR DEAD LOAD AND 1.75 FOR LIVE LOAD, THE MINIMUM REQUIRED BY ASTM F2787 AND BY AASHTO FOR THERMOPLASTIC PIPE.
 - B. A STRUCTURAL EVALUATION SEAL BY A REGISTERED PROFESSIONAL ENGINEER THAT DEMONSTRATES THAT THE LOAD FACTORS SPECIFIED IN THE AASHTO LRFD BRIDGE DESIGN SPECIFICATIONS, SECTION 12.12, ARE MET. THE 50 YEAR CREEP MODULUS DATA SPECIFIED IN ASTM F2418 MUST BE USED AS PART OF THE AASHTO STRUCTURAL EVALUATION TO CERTIFY LONG-TERM PERFORMANCE.
 - C. STRUCTURAL CROSS SECTION DETAIL ON WHICH THE STRUCTURAL EVALUATION IS BASED.
23. CHAMBERS SHALL BE PRODUCED AT AN ISO 9001 CERTIFIED MANUFACTURING FACILITY.
24. PRIOR TO BEGINNING INSTALLATION OF HYDROSTOR STORMWATER CHAMBERS, A PRECONSTRUCTION MEETING SHALL BE HELD WITH A PRINSCO REPRESENTATIVE AND THE INSTALLERS.
25. HYDROSTOR STORMWATER CHAMBERS SHALL BE INSTALLED IN ACCORDANCE WITH THE PRINSCO "HYDROSTOR CONSTRUCTION GUIDE."
26. HYDROSTOR STORMWATER CHAMBERS SHALL NOT BE INSTALLED ON WET OR UNSTABLE FOUNDATION OR SUBGRADE. FOUNDATION STONE MUST BE LEVEL AND COMPACTED.
27. PRINSCO RECOMMENDS PRETREATMENT OF STORMWATER RUNOFF USING A PRINSCO STORMWATER QUALITY UNIT AND/OR A SEDIMENT ROW.
28. MAINTAIN MINIMUM SPACING OF 8.5" (SPECIFICALLY HS290) BETWEEN CHAMBERS.
29. CONSTRUCTION EQUIPMENT SHALL NOT BE SITUATED ATOP THE CHAMBERS UNTIL SUFFICIENT COVER HAS BEEN ACHIEVED. DUMP TRUCKS, RUBBER TIRE LOADERS, EXCAVATORS, WHEEL OR ROLLER LOADS ARE NOT ALLOWED UNTIL PROPER FILL HEIGHTS HAVE BEEN ACHIEVED. REFER TO PRINSCO "HYDROSTOR CONSTRUCTION GUIDE" FOR SPECIFIC LOADING CRITERIA.
30. EMBEDMENT BACKFILL MUST BE PLACED USING THE FOLLOWING METHODS ONLY:
 - A. BACKFILL WITH AN EXCAVATOR LOCATED OUTSIDE THE EXCAVATION
 - B. BACKFILL WITH A STONE SHOOTER LOCATED OUTSIDE THE EXCAVATION
 - C. BACKFILL AS ROWS ARE BUILT WITH AN EXCAVATOR ON THE SUBGRADE OR FOUNDATION STONE
31. EMBEDMENT BACKFILL SHALL NOT BE PLACED USING THE "DUMP AND PUSH" METHOD. THIS MAY CAUSE DAMAGE TO THE CHAMBERS, WILL RESULT IN IMPROPER INSTALLATION AND WILL VOID THE PRINSCO STANDARD WARRANTY.
32. ONCE SUFFICIENT COVER IS ACHIEVED (12" FOR HS290), GRADING MAY COMMENCE WITH A SMALL DOZER OR SKID LOADER (LESS THAN 4.5 PSI GROUND PRESSURE). EQUIPMENT SHALL ALWAYS TRAVEL PARALLEL TO CHAMBER ROWS. SEE PRINSCO "HYDROSTOR CONSTRUCTION GUIDE" FOR SPECIFIC LOADING CRITERIA.

12.0 Sediment Row Inspection & Maintenance

12.1 Sediment Row Inspection

Inspecting and maintaining the HydroStor chamber system is critical to ensuring the stormwater system will perform as designed. Buildup of debris in the chamber system may result in ineffective operation or complete failure of the system. Inspection of chamber sediment row can be done through the manhole or optional inspection ports on the chamber sediment row. All local and OSHA rules must be followed for confined space entry.

Inspection ports offer the convenience of inspection from the ground surface without concern of confined space entry. (Figure 20) Inspection ports allow for visual inspection with the use of a flashlight or a long stick to measure the level of sediment.

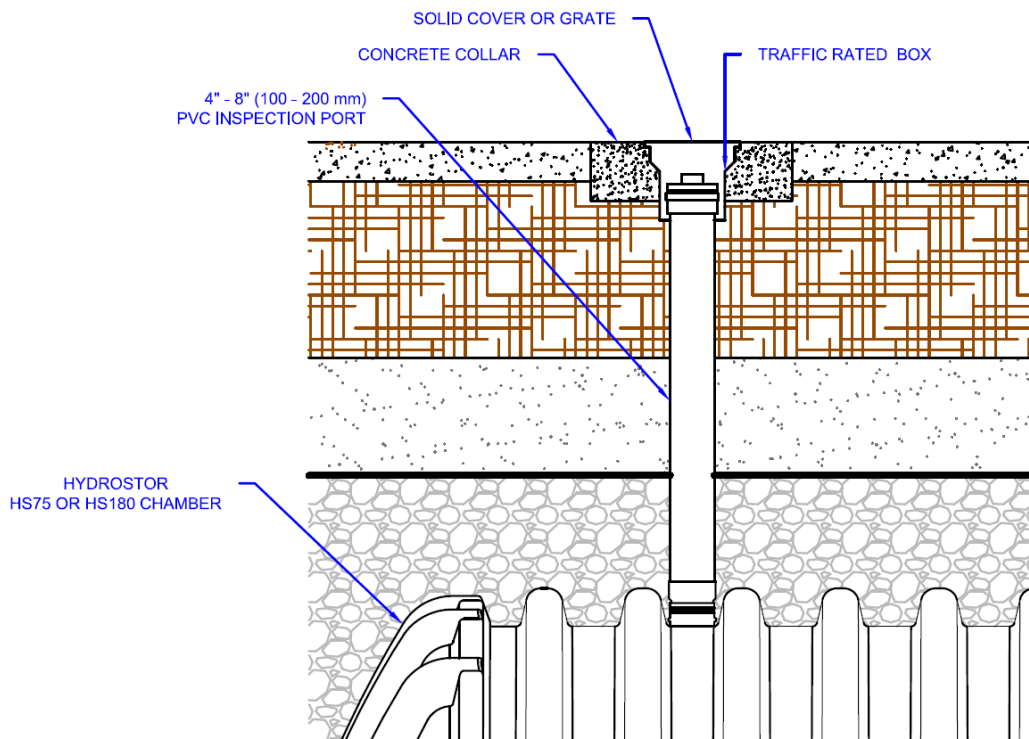

Figure 20 - Inspection Ports for Chamber Sediment Rows

12.2 Inspection Frequency

Initial inspection of the system is recommended soon after the site construction is completed. Every effort should be made to keep sediment and debris out of the stormwater system during construction; however, this is typically the time when excess amounts of sediment builds up. It is recommended that the system be inspected and cleaned, if necessary, before passing the responsibility over to the site owner.

Inspection frequency will vary based on the system design and requirements. A system inspection schedule should be developed for each individual system, with the industry standard being a minimum of twice per year. It is recommended that the inspections be tracked on an Inspection and Maintenance log sheet.

12.3 Sediment Row Maintenance

Maintenance of the chamber sediment row is recommended after an average depth of 3" (75 mm) of sediment has been collected. The most common method for cleaning is done by using a high pressure water jet and a vacuum truck (JetVac system). The sediment should be directed to the inlet control structure sump and vacuumed out. The JetVac process shall only be performed on HydroStor chamber rows that have AASHTO M288 Class 1 woven geotextile over the foundation stone.

13.0 General Notes

1. The installation of HydroStor chamber systems must be done in accordance with the latest published HydroStor Installation/Construction Guidelines. Visit Prinsco's website, www.prinsco.com, for the most up to date installation guidelines.
2. Prinsco offers installation consultations to installing contractors. Contact your local Prinsco representative a minimum of 30 days prior to system installation to arrange a pre-installation consultation. Prinsco representatives are able to answer questions or address comments about the HydroStor chamber systems and explain the minimum installation requirements prior to the system being installed. Call 1-800-992-1725 to speak to a local Prinsco representative.
3. The minimum cover height is 23.5" (590 mm) for HS180 chambers and 24" (600 mm) for HS290 chambers. The minimum cover height is measured from the top of the chambers to the bottom of the pavement (asphalt, concrete, etc.) For installations without pavement, where rutting from vehicles may occur, the minimum cover height should be increased to 30" (750 mm) for the HS180 chambers and HS290 chambers.
4. The maximum cover height for HS180 & HS290 chambers is 8' (2.44 m) measured from the top of the chambers to the top of the pavement.
5. It is the contractor's responsibility to report any discrepancies with the bearing capacity of the subgrade materials to the design engineer.
6. AASHTO M288 Class 2 non-woven geotextile must be used for the separation layer as indicated on the project plans.
7. Stone placement between chamber rows and around the perimeter of the chambers must follow the instructions indicated in the most recent HydroStor Installation/Construction Guidelines.
8. Backfilling over the chambers must follow the requirements indicated in the most recent HydroStor Installation/Construction Guidelines.
9. The contractor must refer to the most recent HydroStor Installation/Construction guidelines for a Table of Acceptable Vehicle Loads at various depths of cover. It is the contractor's responsibility to ensure that vehicles exceeding those listed in the table do not travel over the chambers. The use of temporary fencing, warning tape, and/or signs are commonly used methods to keep oversized vehicles out of the construction zone.
10. The contractor must apply erosion and sediment control measures to protect the chamber system during all phases of site construction based on the local codes and design engineer's requirements.
11. HydroStor chambers are covered under Prinsco's Limited Warranty – Terms & Conditions. Contact your local Prinsco Representative for more information.



When it comes to stormwater chambers, the road from good to great leads directly to HydroStor, the industry's highest performing chambers. They meet or exceed proven ASTM structural, design and product standards, while including features that matter to the designer and installer.

HS180

9" (230 mm) minimum	foundation	9" (230 mm) minimum
8" (200 mm)	chamber spacing	8.5" (216 mm)
77.8" (1,976 mm)	chamber width	100.5" (2,554 mm)
12" (300 mm)	backfill at edge of system	12" (300 mm)
45.5" (1,156 mm)	chamber height	59.5" (1,511 mm)
23.5" (590 mm)	minimum cover	24" (600 mm)
8' (2.44 m)	maximum burial depth	8' (2.44 m)

HS290

Available Sizes



HS180

180 ft ³ (5.1 m ³)/chamber	Installed Storage Capacity*	164 ft ³ (4.64m ³)/chamber
45.5" (1,156 mm)	Height	59.5" (1,511 mm)
77.8" (1,976 mm)	Width	100.5" (2,554 mm)
88.7" (2,253 mm)	Length	51.8" (1,317 mm)
Integrated Handles	Special Features	Integrated Handles
Meets or Exceeds	ASTM Standards	Meets or Exceeds



HS290

Performance

- High performance polypropylene material
- Meets or exceeds **ASTM F2418** product standard & **ASTM F2787** design standard
- Meets **AASHTO H20** live load & **HL93** design load requirements
- Advanced injection molding technology for maximum structural performance

The HydroStor **HS180** stores 25 ft³ of stormwater per linear foot (2.3 m³ per linear meter) or 180 ft³ (5.1 m³) per chamber, and is designed for high-volume projects

The HydroStor **HS290** stores 41 ft³ of stormwater per linear foot (3.75m³ per linear meter) or 164 ft³ (4.65 m³) per chamber, and is designed for high-volume projects.

Prinsco's HydroStor chambers meet rigorous ASTM standards and include value-added design features that take this new chamber option from good to great.

MOBILE RESOURCES



More about **HydroStor™**
 Installation Videos
 Installation Guides
 Specifications
 Technical Notes



Prinsco.com/HydroStor-Resources

COLLECTION & CONVEYANCE



GOLFLO WT®
AASHTO Dual-Wall Pipe



GOLDPRO STORM™
Dual-Wall HP Polypropylene

TREATMENT

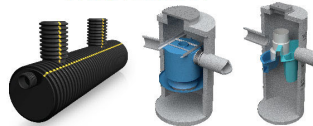

STORMWATER QUALITY
Engineered Water Treatment

STORAGE



HYDROSTOR™
Arched Chambers

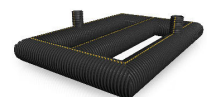

UNDERGROUND DETENTION
Customized Pipe Systems



PRINSCO.COM

800.992.1725