

12"-24" GASKET DETAIL

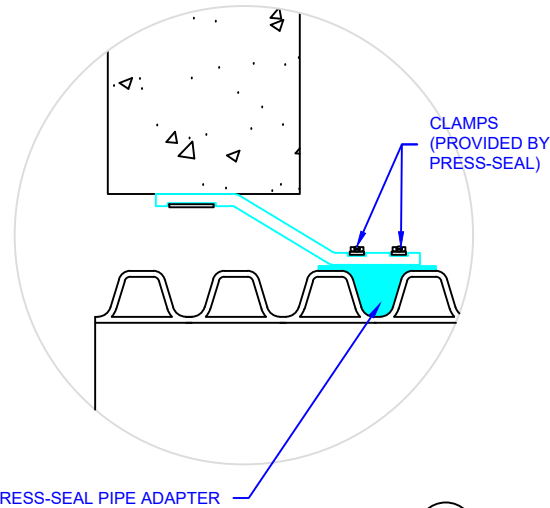

30" GASKET DETAIL

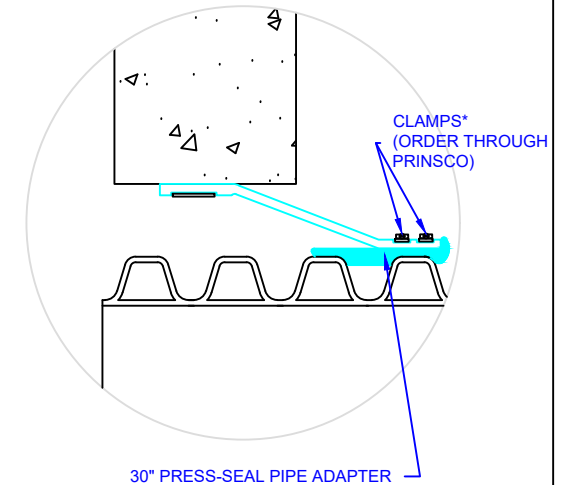

A  
120  
GASKET DETAIL  
SCALE: NTS

PIPE SIZE in (mm)	PIPE OD in (mm)	PRESS-SEAL ADAPTER (PRINSCO P/N)	PRESS-SEAL PSX DIRECT DRIVE CONNECTOR	HOSE CLAMP (PRINSCO P/N)
12 (300)	14.6 (371)	GFAD12MH	18M PSX-2: DD	PROVIDED BY PRESS-SEAL
15 (375)	17.8 (452)	GFAD15MH	22L PSX-2:DD	PROVIDED BY PRESS-SEAL
18 (450)	21.5 (546)	GFAD18MH	26L PSX-2: DD	PROVIDED BY PRESS-SEAL
24 (600)	28.2 (716)	GFAD24MH	32A PSX-2: DD	PROVIDED BY PRESS-SEAL
30 (750)	34.7 (882)	GFAD30MH	40L PSX-2:DD*	GFWT30HTC

\*TO MEET AND EXCEED ASTM F2510 ON THE 30" DIAMETER CONNECTION, HIGH-TORQUE HOSE CLAMPS ARE REQUIRED ON THE PRESS-SEAL DIRECT DRIVE CONNECTOR.

NOTES:

- ADAPTER GASKET MEETS OR EXCEEDS: ASTM F2510, ASTM C1478, ASTM D2321 SECTION 7.10-MANHOLE CONNECTIONS.
- ALL PIPE SHALL BE INSTALLED IN ACCORDANCE WITH ASTM D2321 - STANDARD PRACTICE FOR UNDERGROUND INSTALLATION OF FLEXIBLE THERMOPLASTIC SEWER PIPE, LATEST EDITION.
- SEE PRESS-SEAL FOR SPECIFIC PRODUCT INFORMATION AND SELECTION.
- PRESS-SEAL ADAPTER AND PRESS-SEAL PSX: DIRECT DRIVE ARE A REGISTERED TRADEMARK OF PRESS-SEAL CORPORATION. (WWW.PRESS-SEAL.COM)
- SEE STRUCTURE CONNECTION INSTALLATION DETAIL (D-2-109) FOR PROPER BACKFILLING TECHNIQUES NEAR STRUCTURES.

THIS DETAIL DEPICTS RECOMMENDED INSTALLATION PRACTICES AND IS NOT INTENDED TO SUPERSEDE ANY NATIONAL, STATE OR LOCAL SPECIFICATIONS. PRINSCO BEARS NO RESPONSIBILITY FOR ANY ALTERATIONS, REVISION AND/OR DEVIATION FROM THIS STANDARD DETAIL. PRINSCO HAS NOT PERFORMED ANY ENGINEERING OR DESIGN SERVICE FOR THIS PROJECT. THE DESIGN ENGINEER SHALL REVIEW THESE DETAILS PRIOR TO CONSTRUCTION TO VERIFY SUITABILITY. © PRINSCO, INC.



1717 16TH ST. NE  
WILLMAR, MN 56201  
www.prinSCO.com

TITLE: HP PIPE - STRUCTURE CONNECTION - ADAPTER GASKET			
DRAWN BY: AED	DATE: 02-Aug-22	DRAWING NUMBER: D-2-120	
SCALE: NTS	SHEET: 1 OF 1		