

Introduction

The Prinsco Stormwater Quality Unit (SWQU) effectively removes sediment and oils from runoff water. SWQU design calculations not only consider the removal of sediment, oils, and floatables but are sized to maintain flow rates and volumes as needed per ASTM F2737.

This document highlights proper installation essential for maximizing efficiency and long-term performance. Specifications stated in local, state, and federal laws are to be followed during installation. For more information on design, maintenance, and inspection, or if site conditions or methods are outside of those reflected in this guide, please contact your local Prinsco representative or visit www.prinsco.com.

Selecting Backfill Material

Specific soil classification must be selected for proper installation of the SWQU. Bedding and initial backfill must meet Class I criteria as described in ASTM D2321. Many backfill materials of 1½" (38 mm) and smaller clean, graded, or crushed stones and gravel meet Class I criteria. Various smaller, rounder materials that meet Class II, III, or IVA criteria are unacceptable for bedding and initial backfill, but may be acceptable for final backfill. Table 1 provides additional backfill information.

Table 1: Soil Classifications

Soil Description		Acceptable Soil Placement				
ASTM D2321	ASTM D2487	General Description ⁽¹⁾	Standard Proctor Density	Maximum Layer (Lift) Height	Acceptable Bedding and Initial Backfill	Acceptable Final Backfill (if able to support surface load)
Class I	n/a	Angular, crushed stone or rock with little to no fines	95% ⁽²⁾	12" (0.3 m)	Yes	Yes
Class II	GW, GP, SW, SP	Well-graded or poorly graded gravel, sand, or their mixtures; little to no fines	95%	6" (0.15 m)	No	Yes
Class III	GM, GC, SM, SC	Silty gravel and sand or gravel/sand/silt mixtures. Clayey gravel and sand or gravel/sand/clay mixtures	95%	6" (0.15 m)	No	Yes
Class IVA	ML, CL	Certain inorganic silts and clays, and some very fine sands	95%	6" (0.15 m)	No	Yes

- 1) Refer to ASTM D2321 for a full material description.
- 2) The center portion of the bedding should be loosely placed, not compacted, as described later in this document.

Flowable Fill

Flowable fill is a low-strength concrete that can sometimes be substituted for compacted aggregate as backfill for SWQUs and other structures. Pipe flotation can occur with this backfill and special requirements to prevent flotation need to be taken into consideration.



Trench Construction

The trench width should be as narrow as possible to take advantage of the natural strength of the consolidated in-situ soil, while still allowing enough room for proper compaction of backfill around the pipe. Using installation procedures found in ASTM D2321 and AASHTO Bridge Construction Specifications Section 30, Prinsco recommends trench widths based on pipe diameter as shown in Table 2. When joining the bypass connection, extra trench width is required as displayed in Table 3 and Figure 1.

Table 2: Trench Characteristics

Pipe Size in (mm)	Min. Recommended Trench Width (A) in (mm)	Min. Trench Depth (B) in (mm)
36 (900)	65 (1650)	53 (1350)
42 (1050)	84 (2100)	60 (1500)
48 (1200)	90 (2300)	72 (1800)
60 (1500)	102 (2600)	85 (2150)

Table 3: Bypass Trench Recommendations

Bypass Pipe Size in (mm)	Bypass Pipe Min. Trench Width (C) in (mm)
8 (200)	25 (600)
10 (300)	28 (700)
12 (300)	30 (800)
15 (400)	34 (900)
18 (500)	40 (1000)
24 (600)	50 (1300)
30 (800)	59 (1500)
36 (900)	65 (1700)
42 (1100)	84 (2100)
48 (1200)	90 (2300)
60 (1500)	102 (2600)

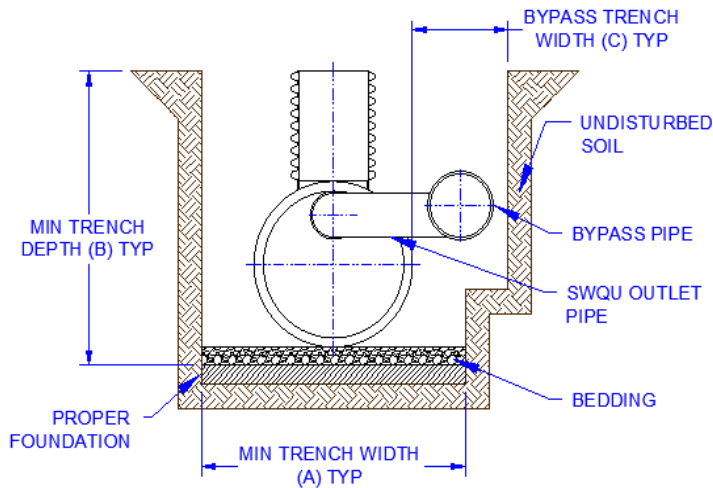

Figure 1: Trench Dimensions

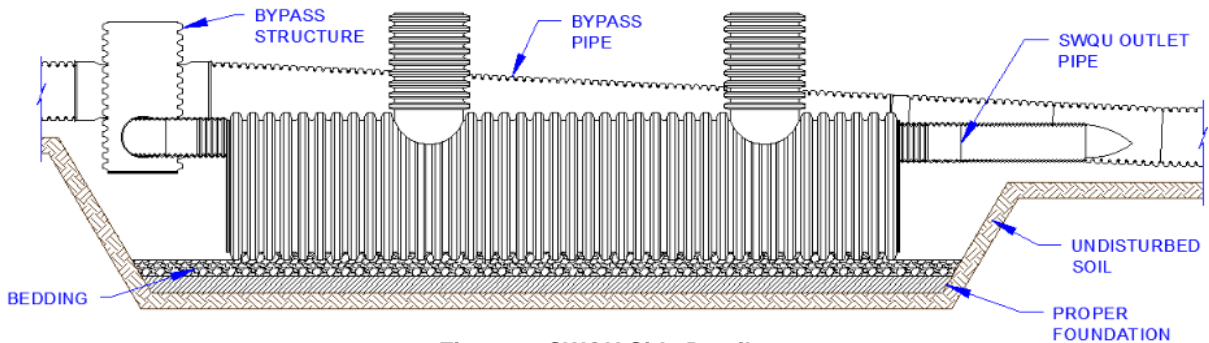

Figure 2: SWQU Side Detail



Some site conditions may need to be altered to create an adequate installation. Reference the following for specific complications during trench construction:

- If there is rock or other rigid material found at the trench bottom, the rigid material must be removed and replaced with 1-foot (0.3 meter) of proper backfill below grade.
- If there are especially soft materials such as muck found at the trench bottom, soft material must be removed and replaced with 2-foot (0.6 meter) of proper backfill below grade.
- Water inside of the trench should be controlled before and during the installation. The SWQU should only be installed during dry conditions, never with running or standing water in the trench bottom.
- Refer Prinsco's Standard Trench Installation (D-1-100) and online installation guides at prinsco.com for more information.

Bedding and Initial Backfill

The bedding of the system is crucial to provide solid groundwork between the foundation and bottom of pipe. Only Class 1 materials are recommended. The outer thirds of the Class 1 should be compacted and the middle one third portion should be loosely placed. Reference Table 4 for minimum depth recommendations.

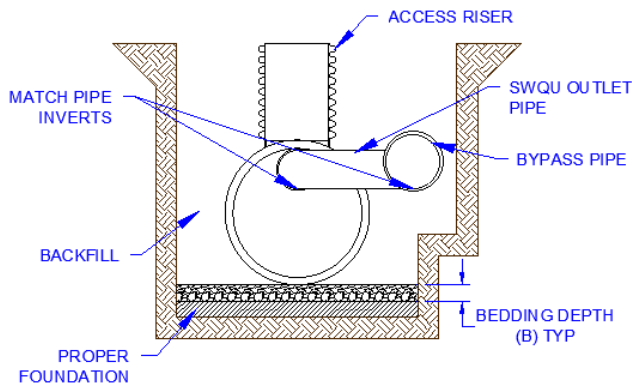

Figure 3: Bedding Placement

Table 4: Bedding Depth Recommendation

Pipe Size in (mm)	Min Recommended Bedding Depth (B) in (mm)
36 (900)	4 (100)
42 (1050)	6 (150)
48 (1200)	6 (150)
60 (1500)	6 (150)

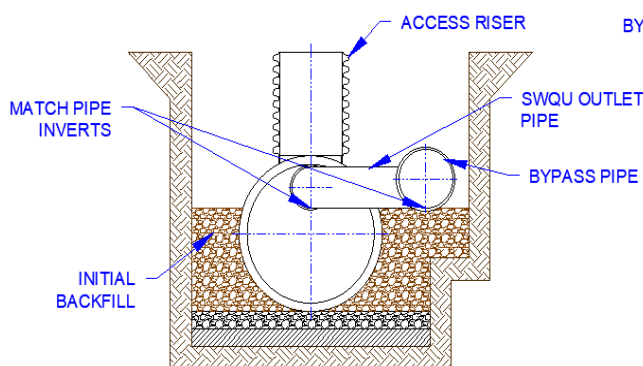

Figure 4: Unit Placement: Outlet End

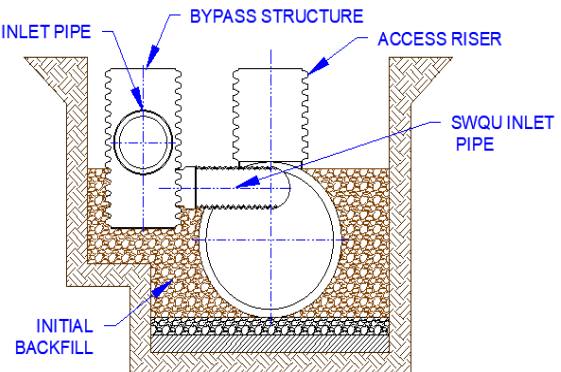

Figure 5: Unit Placement: Inlet End



Unit Placement and Bypass Connection

Special care must be taken when transporting the SWQU. When moving or installing the unit, use nylon sling straps around the main pipe. Do not lift the unit by its risers. If installing a unit with multiple sections, install the outlet section first, lubricate bell and spigot and place the remaining section, securing the joint. To connect the bypass, start by linking the outlet bypass structure to the SWQU outlet fitting. Ensure that the inverts of the SWQU match the inverts of the bypass structure as shown in Figure 4 and Figure 5. Connect the SWQU inlet pipe to the bypass structure.

Initial and Final Backfilling

After the appropriate backfill material has been selected, as shown in Table 1, it must be carefully placed and compacted around the SWQU, as displayed in Figure 6. Take caution during the use of construction or compaction equipment to not strike the SWQU or other associated piping.

Appropriate backfilling steps are outlined below:

- Position the SWQU on the bedding and install initial backfill in layers uniformly around the unit, compacting each layer before adding the next. Initial backfill is required a minimum of 12" (0.3 m) above the SWQU crown. This is shown in Figure 7. Once initial backfill is placed, fill the SWQU, up to the sediment weir plate, with water.
- If the installation will not be trafficked, 12" (0.3 m) minimum initial backfill over the crown is adequate.
- If the installation will be experiencing trafficked loading, 12" (0.6 m) minimum of initial and 12" (0.6 m) minimum final backfill over top of pipe is required. Table 1 describes backfill options and minimum compaction levels for final backfill.
- In trafficked installations, a concrete collar is also required around each riser. Initial backfill material should be placed at least 6" (0.15 m) around each riser to properly support a recommended 12" minimum concrete collar around each riser, as shown in Figure 7. The selected frame and grate, sold by others, must be able to support the traffic load.

Construction vehicles may result in temporary loads more than the design load. Contact your local Prinsco Representative for procedures to manage these loads without damaging the SWQU.

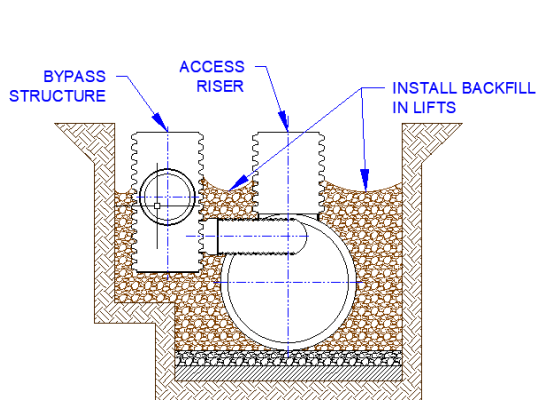

Figure 6: Initial Backfill

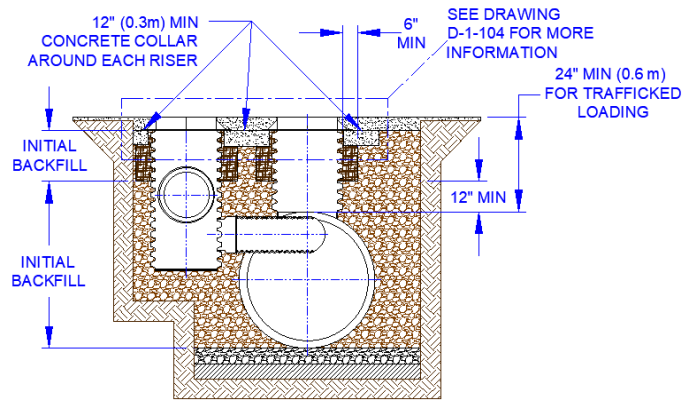

Figure 7: Final Backfill