

A culvert system allows water to flow freely under a road or driveway, preventing any flooding along the roadway or nearby property. The corrugated, plastic pipe provides an efficient and long lasting solution to culvert drainage needs. This guide is to assist homeowners and contractors on how to properly install the product in a culvert application.

PRODUCT MATERIALS



8"-60" GOLDFLO® or GOLDLINE® Pipe

Estimate length and round up to nearest 20' length.

NOTE: Account for extra pipe on each end to extend beyond slope of driveway.

Cut pipe with saw in valley between corrugations to any length.

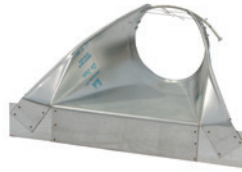

Aprons (2)

Installed on pipe ends, aprons divert water in and away from culvert openings.

Match to pipe diameter.



Split Coupler(s)

Couplers join two lengths of pipe. Match to pipe diameter.

Other tools and equipment needed: shovel, skid loader or excavator, compaction equipment, reciprocating or hand saw, personal protective equipment (PPE).

⚠ Before you Dig

- Call 811 for utility locations.
- Check state and local culvert requirements.

CULVERT INSTALLATION

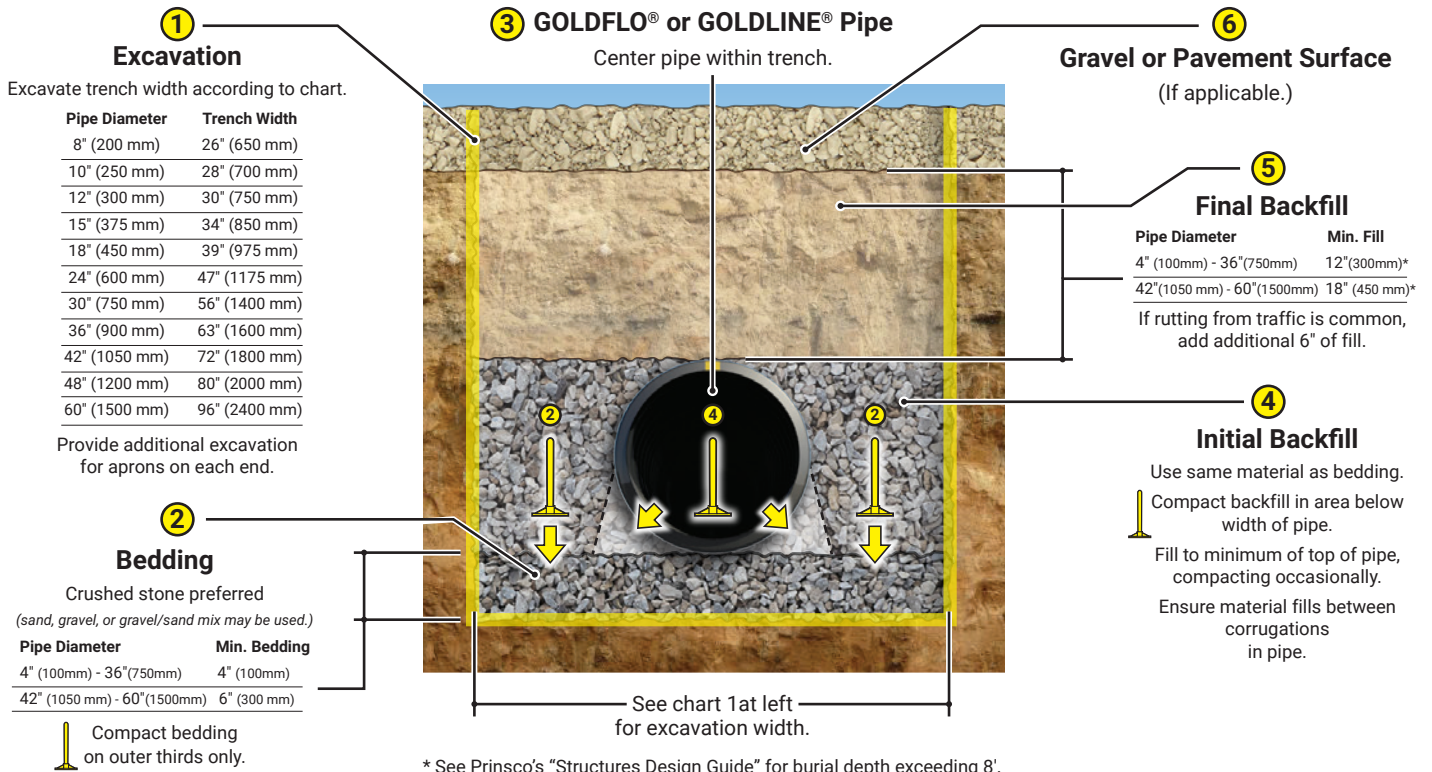

ACCESSORY INSTALLATION

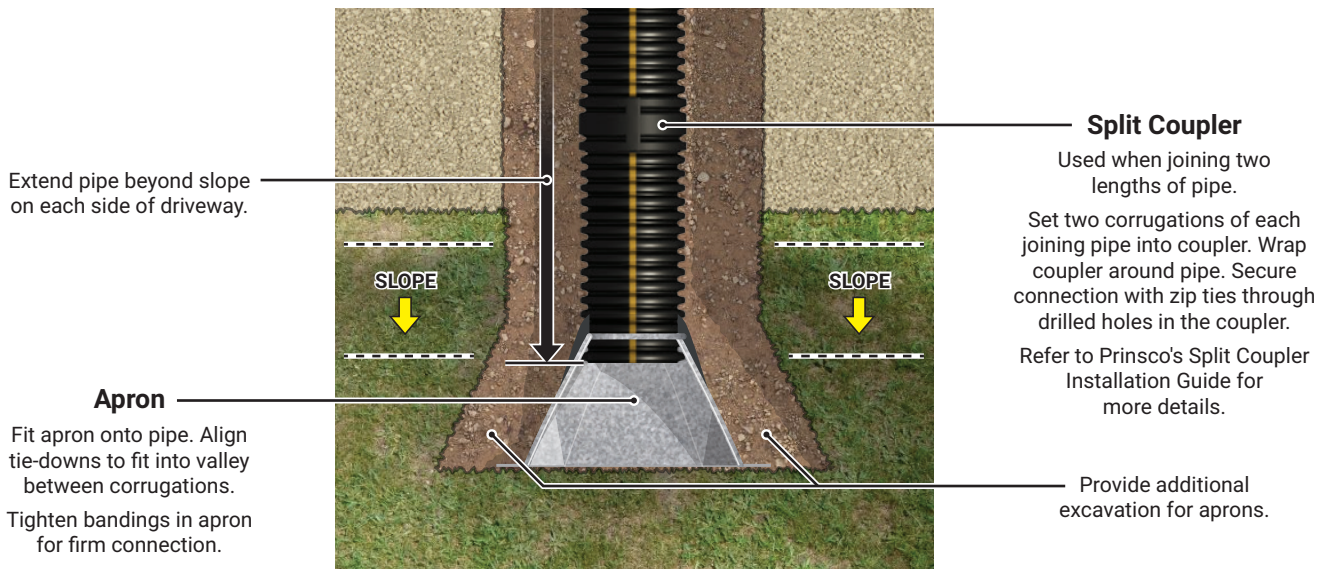

LOADING CAPABILITIES

Buried corrugated HDPE culverts are rated for H-25/HS-25 loading, provided there is a minimum amount of cover over the pipe and proper soil support around the pipe.

See illustration below for H-25 and HS-25 vehicular loads based on AASHTO vehicle configurations showing the two truck configurations and the associated loading distribution. Heavier axle loads may be possible with special installation practices. For pipe diameters up to 36", a minimum of 12" of cover is recommended if pavement is used and 18" of cover with no pavement over the pipe. Visit www.Prinsco.com for additional information.

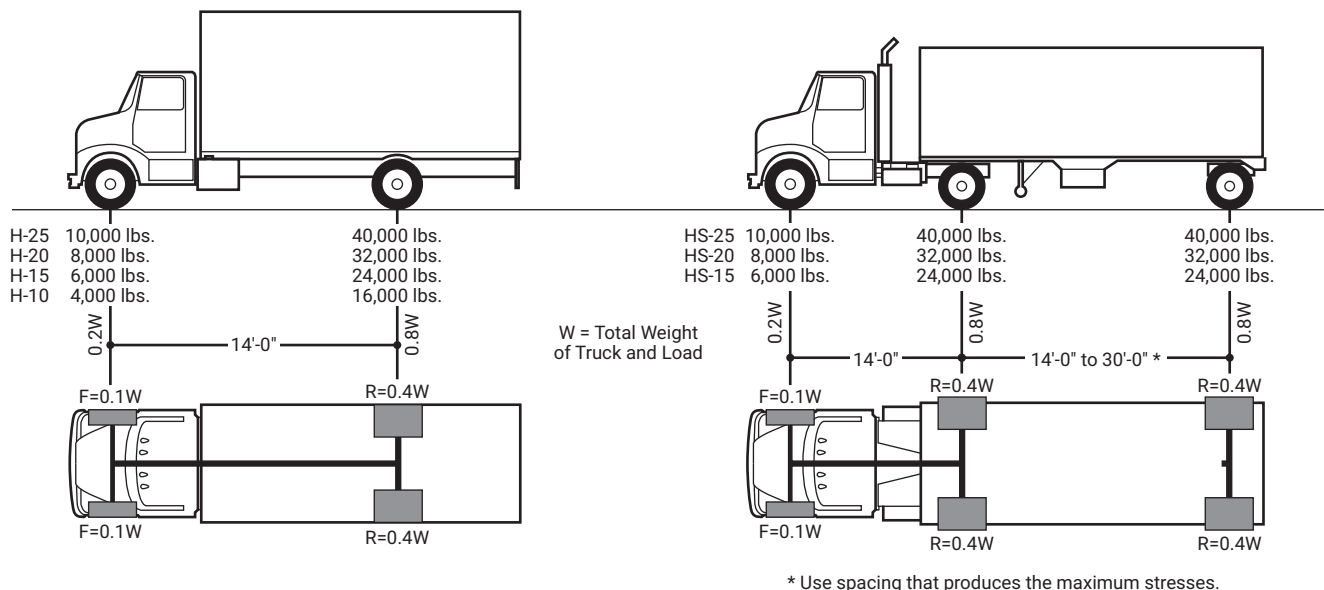

Source: AASHTO Standard Specifications for Highway Bridges