

Chamber Specifications	
Chamber Size (L x W x H)	87.8" x 34" x 16" (2,230 x 864 x 406 mm)
Installed Length	85.4" (2,169 mm)
Chamber Storage	14.9 ft ³ (0.42 m ³)
Min. Installed Storage*	31.1 ft ³ (0.88 m ³)
Weight / Chamber	32 lbs (15 kg)
Chambers / Pallet	45
Approx. Weight / Pallet	1,630 lbs (739 kg)

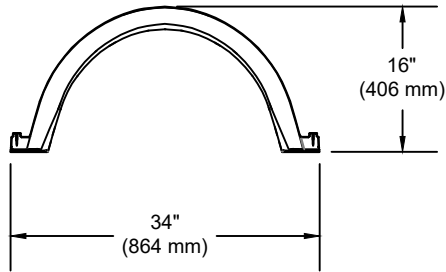

End Cap Specifications	
End Cap Size (L x W x H)	7.4" x 33" x 16" (188 x 838 x 406 mm)
Installed Length	5.1" (130 mm)
End Cap Storage	0.47 ft ³ (0.08 m ³)
Min. Installed Storage*	4.69 ft ³ (0.13 m ³)
Weight	~ lbs (~ kg)

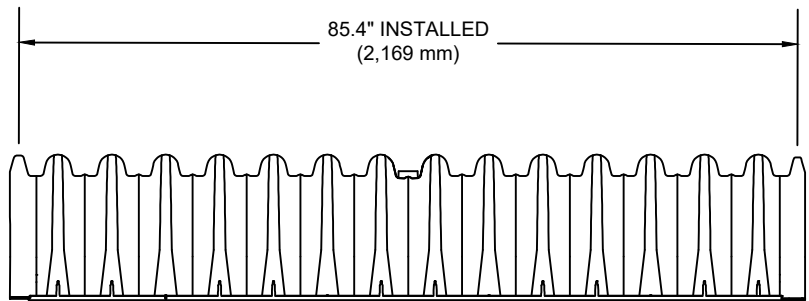
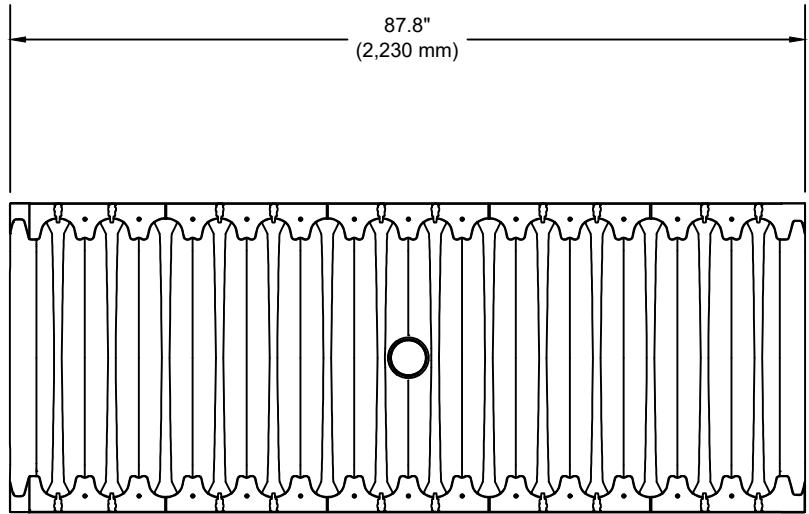
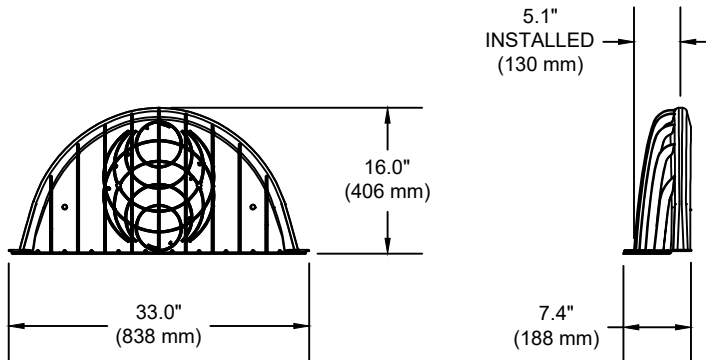

*ASSUMES 6" (150 mm) STONE ABOVE CHAMBERS/END CAPS, 6" (150 mm) OF STONE FOR FOUNDATION STONE, 6" (150 mm) OF STONE BETWEEN CHAMBERS/END CAPS, 12" (300 mm) OF STONE PERIMETER IN FRONT OF END CAPS AND 40% STONE POROSITY.

THIS DETAIL DEPICTS RECOMMENDED INSTALLATION PRACTICES AND IS NOT INTENDED TO SUPERSEDE ANY NATIONAL, STATE OR LOCAL SPECIFICATIONS. PRINSCO BEARS NO RESPONSIBILITY FOR ANY ALTERATIONS, REVISION AND/OR DEVIATION FROM THIS STANDARD DETAIL. PRINSCO HAS NOT PERFORMED ANY ENGINEERING OR DESIGN SERVICE FOR THIS PROJECT. THE DESIGN ENGINEER SHALL REVIEW THESE DETAILS PRIOR TO CONSTRUCTION TO VERIFY SUITABILITY. © PRINSCO, INC.



1717 16TH ST. NE
WILLMAR, MN 56201
www.prinSCO.com

TITLE: HYDROSTOR HS31 - SPECIFICATION			
DRAWN BY: SLE	DATE: 28-Aug-20	DRAWING NUMBER:	
SCALE: NTS	SHEET: 1 OF 1	D-7-401	