

Chamber Specifications	
Chamber Size (L x W x H)	51.8" x 100.5" x 59.5" (1,317 x 2,554 x 1,511 mm)
Installed Length	48.3" (1,227 mm)
Chamber Storage	109.6 ft ³ (3.10 m ³)
Min. Installed Storage*	164.5 ft ³ (4.66 m ³)
Weight / Chamber	112 lbs (50.80 kg)
Chambers / Pallet	10
Approx. Weight / Pallet	1,350 lbs (612 kg)

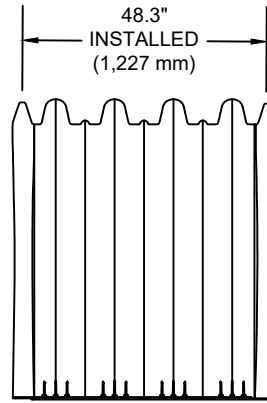

End Cap Specifications	
End Cap Size (L x W x H)	35.0" x 94.0" x 59.3" (889 x 2,388 x 1,506 mm)
Installed Length	32.4" (823 mm)
End Cap Storage	39.6 ft ³ (1.12 m ³)
Min. Installed Storage*	114.46 ft ³ (3.10 m ³)
Weight	79.9 lbs (36.24 kg)

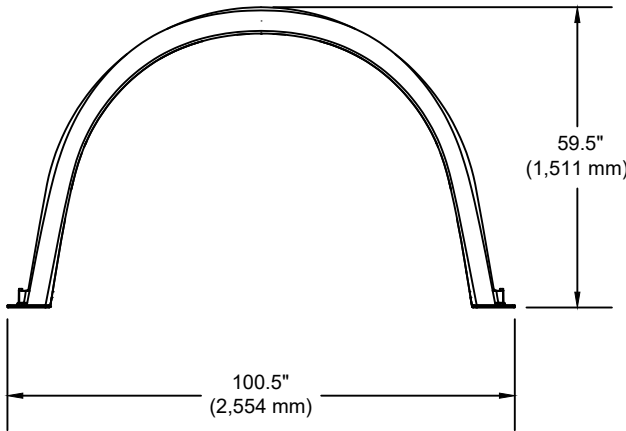
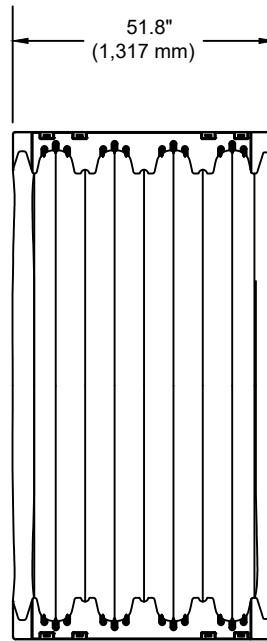
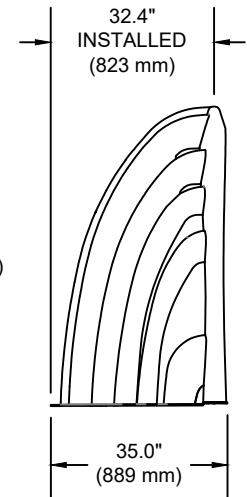
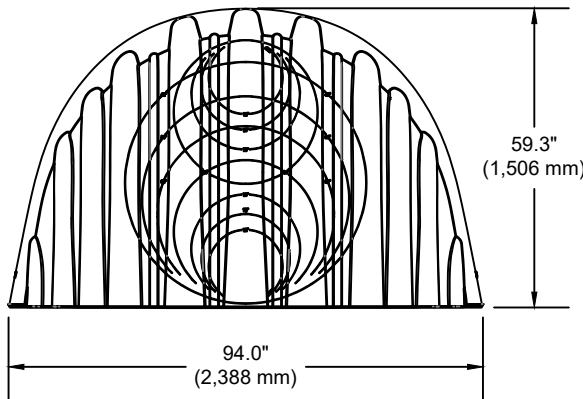

*ASSUMES 12" (300 mm) STONE ABOVE CHAMBERS/END CAPS, 9" (230 mm) OF STONE FOR FOUNDATION STONE, 9" (230 mm) OF STONE BETWEEN CHAMBERS/END CAPS, 12" (150 mm) OF STONE PERIMETER IN FRONT OF END CAPS AND 40% STONE POROSITY.

THIS DETAIL DEPICTS RECOMMENDED INSTALLATION PRACTICES AND IS NOT INTENDED TO SUPERSEDE ANY NATIONAL, STATE OR LOCAL SPECIFICATIONS. PRINSCO BEARS NO RESPONSIBILITY FOR ANY ALTERATIONS, REVISION AND/OR DEVIATION FROM THIS STANDARD DETAIL. PRINSCO HAS NOT PERFORMED ANY ENGINEERING OR DESIGN SERVICE FOR THIS PROJECT. THE DESIGN ENGINEER SHALL REVIEW THESE DETAILS PRIOR TO CONSTRUCTION TO VERIFY SUITABILITY. © PRINSCO, INC.



1717 16TH ST. NE
WILLMAR, MN 56201
www.prinSCO.com

TITLE: HYDROSTOR HS290 - SPECIFICATION			
DRAWN BY: SLE	DATE: 27-Jul-22	DRAWING NUMBER:	
SCALE: NTS	SHEET: 1 OF 1	D-7-501	