

DETAIL A:  
THERMOPLASTIC LINER DETAIL

**NOTES:**

1. REFERENCE "TYPICAL RET/DET CROSS SECTION (D-5-101)" FOR ALL ACCEPTABLE FILL MATERIAL & PROPER INSTALLATION OF PIPE SYSTEM.
  2. THERMOPLASTIC LINER ON BOTTOM AND SIDES OF SYSTEM ONLY.
  3. THERMOPLASTIC LINERS OPTIONS INCLUDE:
    - POLYVINYL CHLORIDE (PVC), 30 MIL PVC
    - LINEAR LOW DENSITY POLYETHYLENE (LLDPE), 30 MIL LLDPE
    - REINFORCED POLYPROPYLENE (RPP), EPDM, AND XR-5
  4. 6 oz/yd<sup>2</sup> NON-WOVEN GEOTEXTILE SHALL BE PLACED ON BOTH SIDES OF THERMOPLASTIC TO PROTECT AGAINST ANGULAR AGGREGATE ON THE WATER SIDE AND FROM PROTRUSION ON THE SOIL SIDE AT ANY LOCATION IN THE SYSTEM (SEE THERMOPLASTIC LINER DETAILS)
  5. THERMOPLASTIC LINER AND PIPE BOOTS SHALL BE INSTALLED PER THE MANUFACTURERS INSTALLATION RECOMMENDATIONS.
- 5A- A PIPE BOOT WITH CLAMP IS RECOMMENDED WHEN PIPE PENETRATES THOUGH THE LINER. BOOTS CAN EITHER BE PREFABRICATED BY THE LINER MANUFACTURE OR FIELD FABRICATED BY THE CONTRACTOR.
- 5B- FOR A WATERTIGHT BOOTED CONNECTION, IT IS RECOMMENDED TO TRANSITION TO A SMOOTH WALL PIPE (E.G. PVC). THIS CAN BE DONE IN MANY WAYS: MARMAC DISSIMILAR COUPLER, FERNCO COUPLER, HARCO HUB X SDR35 SPIGOT ADAPTER WITH GASKET, OR ANY OTHER APPROVED CONNECTOR TO TRANSITION FROM CORRUGATED PLASTIC PIPE. THE PROJECT ENGINEER SHALL DECIDE ON WHAT PIPE MATERIAL PENETRATES THE LINER.

ONE LAYER OF 6 oz/yd<sup>2</sup> NON-WOVEN GEOTEXTILE ABOVE EMBEDMENT BACKFILL (WHERE REQUIRED BY ENGINEER)

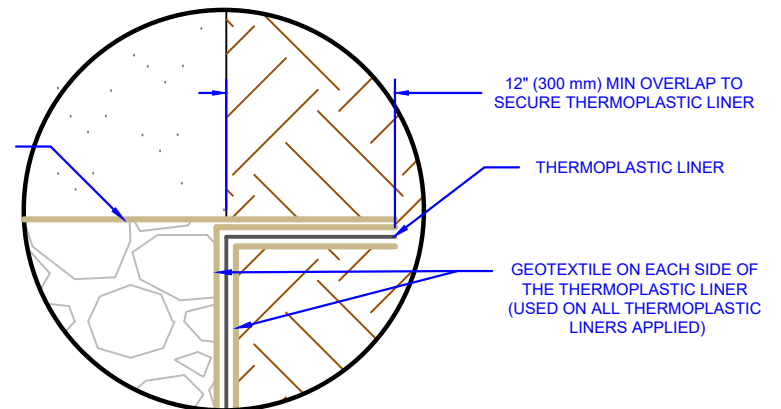

THIS DETAIL DEPICTS RECOMMENDED INSTALLATION PRACTICES AND IS NOT INTENDED TO SUPERSEDE ANY NATIONAL, STATE OR LOCAL SPECIFICATIONS. PRINSCO BEARS NO RESPONSIBILITY FOR ANY ALTERATIONS, REVISION AND/OR DEVIATION FROM THIS STANDARD DETAIL. PRINSCO HAS NOT PERFORMED ANY ENGINEERING OR DESIGN SERVICE FOR THIS PROJECT. THE DESIGN ENGINEER SHALL REVIEW THESE DETAILS PRIOR TO CONSTRUCTION TO VERIFY SUITABILITY. © PRINSCO, INC.



1717 16TH ST. NE  
WILLMAR, MN 56201  
www.prinSCO.com

TITLE:		PIPE SYSTEM- CROSS SECTION - DETENTION	
DRAWN BY:	TJW	DATE:	29-Jul-20
SCALE:	NTS	SHEET:	1 OF 1
		DRAWING NUMBER: D-5-103	