

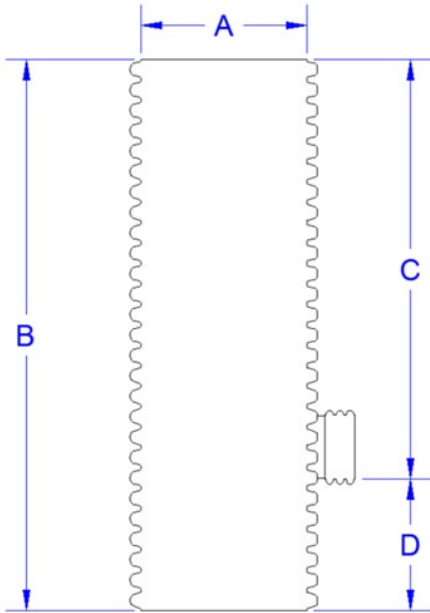

Custom Catch Basin Form			
Customer		Project Name	
Project Location		Sales Rep.	

Installation Considerations

Proper backfill and installation of corrugated HDPE pipe in vertical applications is critical for long term performance. If backfill is not properly placed and compacted around pipe, soil consolidation may cause the basin to compress and shrink in height, stressing and/or damaging the riser and stubs. In live loading applications, a concrete collar and proper grate must be installed to distribute live loading into the surrounding soil and away from the pipe. Reference drawings D-1-105 and D-1-106 for installation details.



Catch Basin Table	
[A] Diameter (in)	[B] Total Height* (ft - in)
Welded Bottom Plate (Y/N)	OD Wrapped* (Y/N)

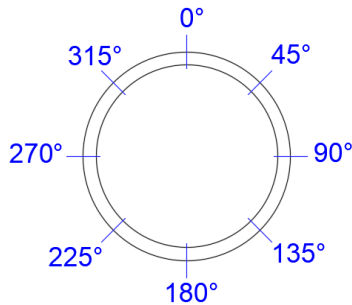

*Basins over 8-ft tall, and 36-in diameter and above, are recommended to be wrapped in sheeting. Basins over 12-ft tall are not recommended.

Stub Table					Stub Types
Stub #	Stub Diameter (in)	Stub Location (° from Diagram)	[C] Stub Invert (in)	Stub Type (Plain End, OSB, IB, Spigot, Other)	
1					Plain End – Standard pipe corrugation without bell or spigot OSB - Oversized bell to fit over full pipe corrugation with gasket IB - Factory extruded pipe integral bell (to connect spigot) Spigot - Factory extruded pipe spigot (to connect integral bell)
2					
3					
4					

Dimensions will be rounded to account for adequate placement on pipe corrugations. Sump Depth [D] is 6" minimum, measured from the lowest stub invert.

NOTES:

WARNING! Risk of Injury or Death Installation of this product must be secured with a locking lid. Open or unsecured product creates a risk of serious injury or death to adults, children, or animals that may enter or fall into this product.
Custom Products – Custom fabricated parts are non-returnable.

The undersign hereby approves the custom design requirements and risk listed above:

Project Representative Signature: _____ Date: _____



Minimum Angle Between Catch Basin Stubs								
Stub Sizes	Catch Basin Diameter							
	12"	15"	18"	24"	30"	36"	42"	48"
4"-4"	80	65	55	40	35	30	25	25
6"-4"	90	70	60	45	35	30	25	25
6"-6"	100	80	65	50	40	35	30	25
8"-4"	105	80	65	50	40	35	30	25
8"-6"	115	90	75	55	45	40	35	30
8"-8"	125	100	80	60	50	40	35	30
10"-4"	115	90	75	55	45	40	35	30
10"-6"	130	100	80	60	50	40	35	30
10"-8"	140	105	90	65	55	45	40	35
10"-10"	155	115	95	70	55	50	40	35
12"-4"	150	100	85	60	40	40	35	30
12"-6"	160	110	90	65	55	45	40	35
12"-8"	175	120	95	70	55	50	40	35
12"-10"	180	130	105	75	60	50	45	40
12"-12"		140	110	80	65	55	45	40
15"-4"		140	95	70	55	45	40	35
15"-6"		145	105	75	60	50	45	35
15"-8"		155	110	80	65	55	45	40
15"-10"		165	120	85	65	55	50	40
15"-12"		175	125	90	70	60	50	45
15"-15"			140	100	80	65	55	50
18"-4"			130	80	60	50	45	40
18"-6"			140	85	65	55	45	40
18"-8"			145	90	70	60	50	45
18"-10"			150	95	75	60	55	45
18"-12"			160	100	80	65	55	50
18"-15"			175	110	85	70	60	50
18"-18"				120	90	75	65	55
24"-4"				120	80	65	55	45
24"-6"				120	80	65	55	50
24"-8"				125	85	70	60	50
24"-10"				135	90	75	60	55
24"-12"				140	95	75	65	55
24"-15"				150	100	80	70	60
24"-18"				160	110	85	75	65
24"-24"					125	100	85	70
30"-4"					115	80	65	55
30"-6"					120	80	65	60
30"-8"					125	85	70	60
30"-10"					125	90	75	65
30"-12"					130	90	75	65
30"-15"					140	95	80	70
30"-18"					145	100	85	75
30"-24"					160	115	95	80
30"-30"						130	105	90

