



Design & Installation Manual Florida



Florida Department of
Environmental Protection. 4/30/2026

Table of Contents

PRO4 24 PRODUCT SPECIFICATION SHEET

PRO4 24 SYSTEM SIZING

TRENCH SYSTEM LAYOUT

MOUND SYSTEM LAYOUT

BED SYSTEM LAYOUT

INSTALLATION INSTRUCTIONS - TRENCH

INSTALLATION INSTUCTIONS - MOUND

INSTALLATION INSTRUCTIONS - BED

INSTALLATION MANUAL - LOW PRESSURE

90 DEGREE BEND LAYOUT

FILTER FABRIC

HOMEOWNER'S GUIDE

LIMITED WARRANTY



PRO 4TM/24

onsite chambers by Prinsco

Pro4/24 Specifications

Chamber Size (L x W x H)	55" x 22" x 12" (1397 x 559 x 305 mm)
Effective Length	48" (1219 mm)
Chamber Storage	32 gal (122 L)
Sidewall Height	8.5" (216 mm)
Open Bottom Area	6.4 ft ² (0.6 m ²)
Weight	11 lbs (5 kg)

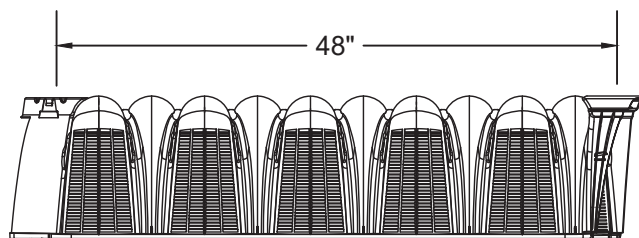
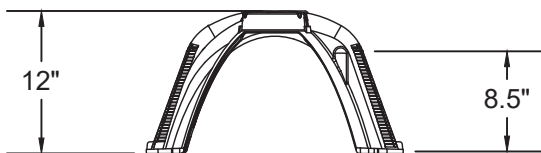
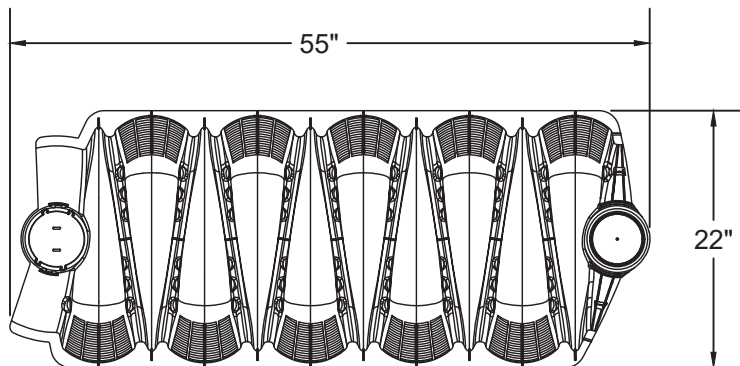

CHAMBER LOADING

Pro4/24 chambers meet H-10 loading requirements which support axle loads up to 16,000 lbs when installed with 12" minimum cover over the chamber. See the Pro4 Installation guides for more information. **Note:** Florida rule does not allow any vehicular traffic for this system. See installation manual for vehicle traffic only during installation.

CHAMBER COUPLING

Pro4/24 chamber coupling supports a pivot of 10 degree left or right. Each coupler has a locking mechanism and the capability to support a 4" inspection port. The direction of installation is located on top of the chamber.

Pro4/24 Endcap Specifications

Endcap Size (L x W x H)	16" x 20" x 12" (406 x 508 x 305 mm)
Effective Length	13" (330 mm)
Invert Elevations	0.5", 6", 7", 12"
Endcap Storage	4.5 gal (17 L)
Weight	2.7 lbs (1.2 kg)

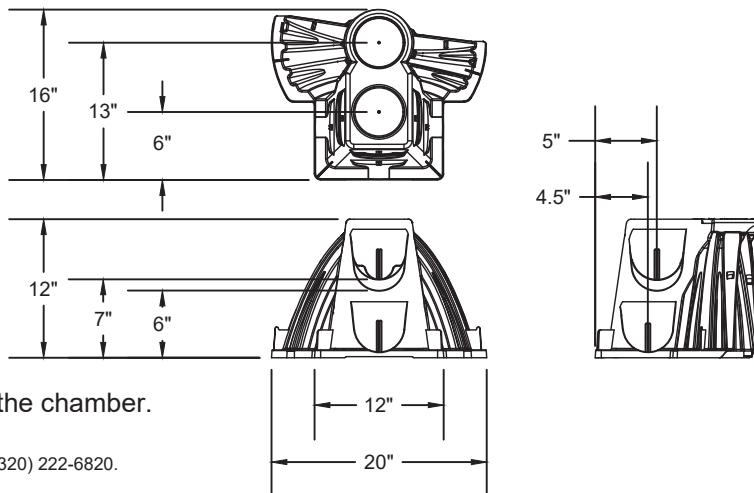

Pro4/24 Endcap can be installed at either end of the chamber.

Prinsco's Pro4 Limited Warranty is available at www.Prinsco.com or call (320) 222-6820.

For questions and technical support: Please contact Prinsco Technical Services at (320) 222-6820 or visit us at www.Prinsco.com.

THIS DETAIL DEPICTS RECOMMENDED INSTALLATION PRACTICES AND IS NOT INTENDED TO SUPERSEDE ANY NATIONAL, STATE OR LOCAL SPECIFICATIONS. PRINSCO BEARS NO RESPONSIBILITY FOR ANY ALTERATIONS, REVISION AND/OR DEVIATION FROM THIS STANDARD DETAIL. PRINSCO HAS NOT PERFORMED ANY ENGINEERING OR DESIGN SERVICE FOR THIS PROJECT. THE DESIGN ENGINEER SHALL REVIEW THESE DETAILS PRIOR TO CONSTRUCTION TO VERIFY SUITABILITY. © PRINSCO, INC.



1717 16TH ST. NE
WILLMAR, MN 56201
www.prinsco.com

TITLE: PRO4/24 - SPECIFICATION DETAIL		
DRAWN BY: ZJJ	DATE: 23-Sep-22	DRAWING NUMBER:
SCALE: NTS	SHEET: 1 OF 1	TN-5-012

Pro4 24 Chamber System Sizing

Table 1: Chamber Properties

Chamber Model	Rating (ft ² /chamber)	Trench Width (in)	Bed Spacing (Min.) (in)
Pro4/24	12	24	4

Table 2: Pro4/24 Bed System Width Minimum Separation

Bed Rows	Pro4/24
2	4'-0"
3	6'-2"
4	8'-4"
5	10'-6"
6	12'-8"
7	14'-10"
8	17'-0"
9	19'-2"
10	21'-4"

Note 1: See Table 1 for bed spacing.
2: Measurements are to outside of chamber edge.

Table 3: Pro4/24 Trench System Widths 24" Spacing

Trench Rows	Pro4/24
2	5'-8"
3	9'-6"
4	13'-4"
5	17'-2"
6	21'-0"
7	24'-10"
8	28'-8"
9	32'-6"
10	36'-4"

Note 1: For 22" wide products, add 3'10" for each additional trench in excess of 10 trenches

Table 4: Pro4/24 Length and Rating

Chamber Qty	Length (ft)	Rating (ft ²)
1	4	12
2	8	24
3	12	36
4	16	48
5	20	60
6	24	72
7	28	84
8	32	96
9	36	108
10	40	120
11	44	132
12	48	144
13	52	156
14	56	168
15	60	180
16	64	192
17	68	204
18	72	216
19	76	228
20	80	240
21	84	252
22	88	264
23	92	276
24	96	288
25	100	300
26	104	312
27	108	324
28	112	336
29	116	348
30	120	360
31	124	372
32	128	384
33	132	396
34	136	408
35	140	420
36	144	432
37	148	444
38	152	456
39	156	468
40	160	480

Note 1: For minimum sizing of standard and split systems (grey water) reference Chapter 62-6 Florida Code.

2: Line lengths can not exceed 100' with the exception in low pressure dosing systems.

TYPICAL TRENCH - CROSS SECTION
(NOT TO SCALE)

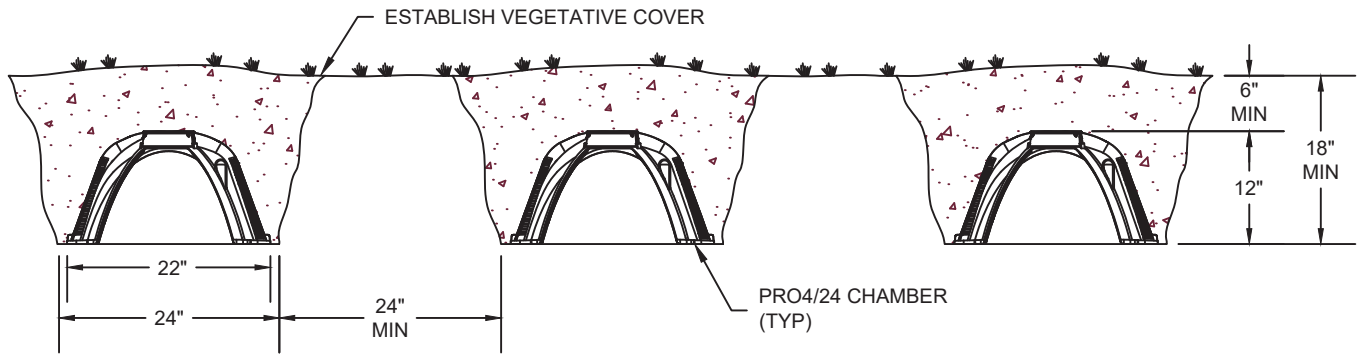

TYPICAL TRENCH - PLAN VIEW
(NOT TO SCALE)

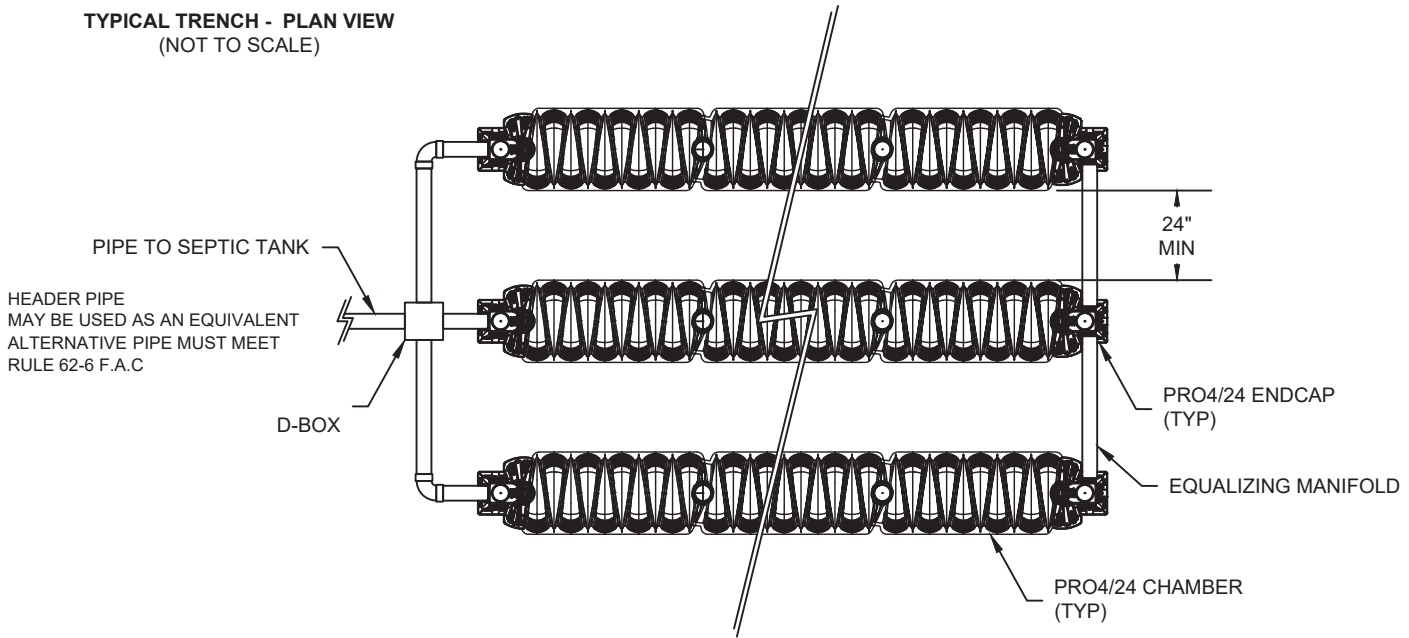

TYPICAL TRENCH - PLAN VIEW
(NOT TO SCALE)

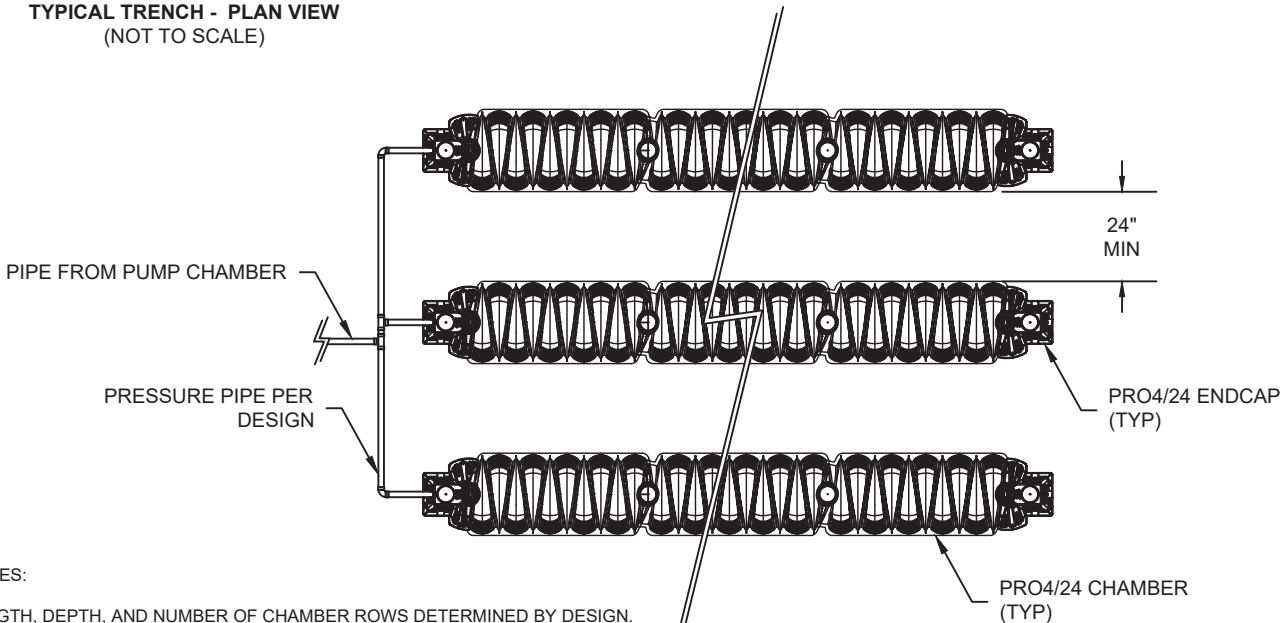

NOTES:
 LENGTH, DEPTH, AND NUMBER OF CHAMBER ROWS DETERMINED BY DESIGN.
 CONFIGURATIONS SHOWN APPLY TO GRAVITY, PUMP, DOSING, AND LOW PRESSURE SYSTEM TYPES.

LOOPING DISTAL ENDS FOR LPP SYSTEMS IS PROHIBITED. LOOPING DISTAL ENDS FOR BED AND MOUND SYSTEMS IN GRAVITY APPLICATIONS IS REQUIRED PER 62-6 FAC.

THIS DETAIL DEPICTS RECOMMENDED INSTALLATION PRACTICES AND IS NOT INTENDED TO SUPERSEDE ANY NATIONAL, STATE OR LOCAL SPECIFICATIONS. PRINSCO BEARS NO RESPONSIBILITY FOR ANY ALTERATIONS, REVISION AND/OR DEVIATION FROM THIS STANDARD DETAIL. PRINSCO HAS NOT PERFORMED ANY ENGINEERING OR DESIGN SERVICE FOR THIS PROJECT. THE DESIGN ENGINEER SHALL REVIEW THESE DETAILS PRIOR TO CONSTRUCTION TO VERIFY SUITABILITY. © PRINSCO, INC.



1717 16TH ST. NE
 WILLMAR, MN 56201
 www.prinSCO.com

TITLE: PRO4 TRENCH DETAIL			
DRAWN BY: RMA	DATE: 14-Jun-24	DRAWING NUMBER:	
SCALE: NTS	SHEET: 1 OF 1	X-#-###	

TYPICAL MOUND - CROSS SECTION
(NOT TO SCALE)

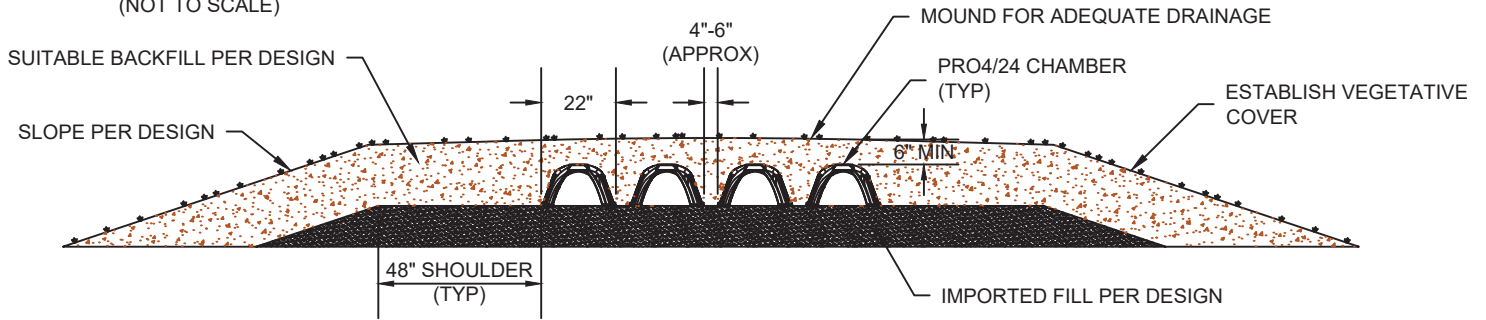

TYPICAL MOUND - PLAN VIEW
(NOT TO SCALE)

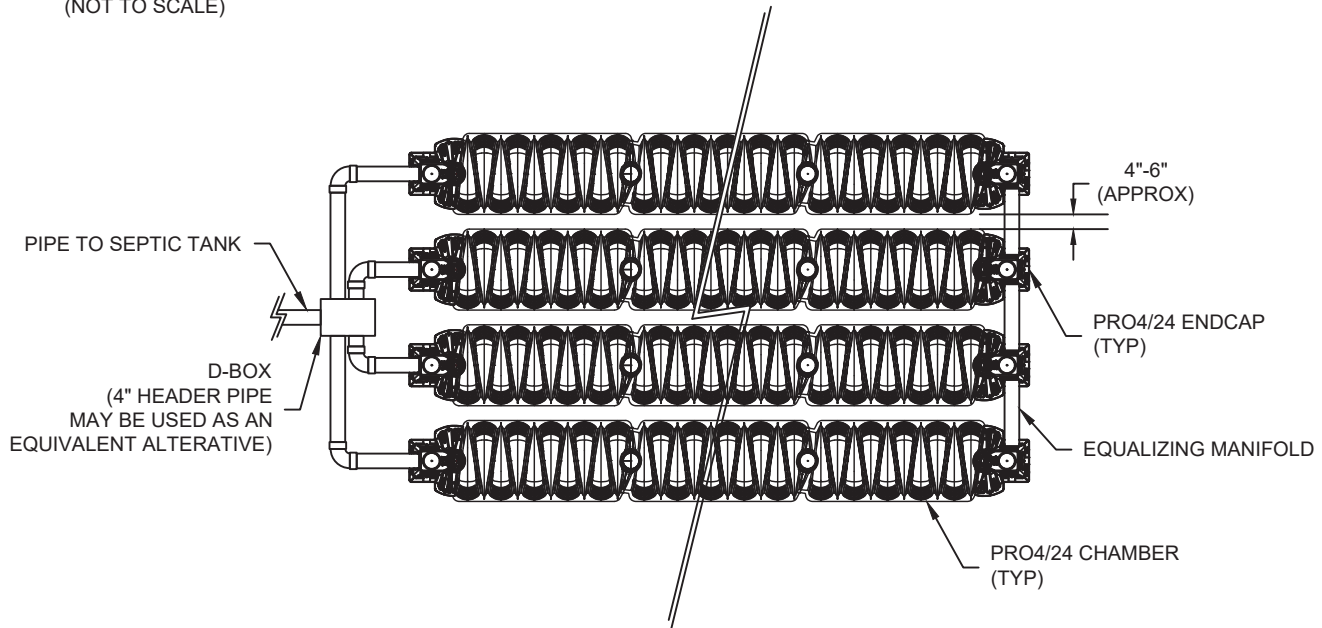

TYPICAL MOUND - PLAN VIEW
(NOT TO SCALE)

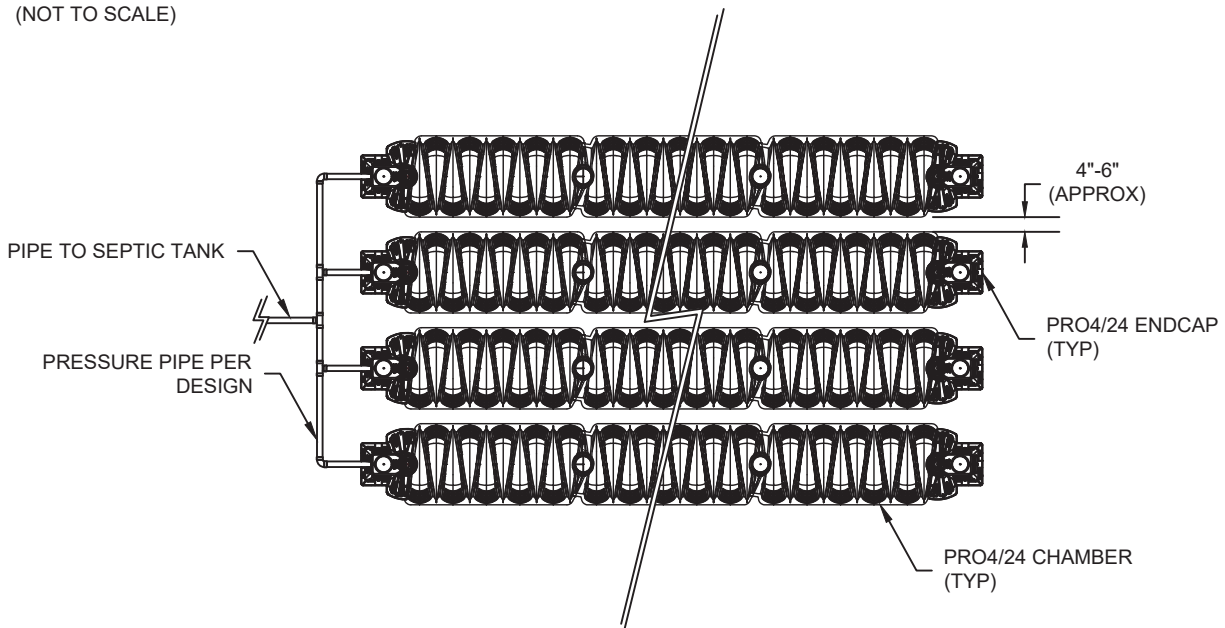

NOTES:

1. LENGTH, DEPTH, AND NUMBER OF CHAMBER ROWS DETERMINED BY DESIGN.
2. CONFIGURATIONS SHOWN APPLY TO GRAVITY, PUMP, DOSING, AND LOW PRESSURE SYSTEM TYPES.

THIS DETAIL DEPICTS RECOMMENDED INSTALLATION PRACTICES AND IS NOT INTENDED TO SUPERSEDE ANY NATIONAL, STATE OR LOCAL SPECIFICATIONS. PRINSCO BEARS NO RESPONSIBILITY FOR ANY ALTERATIONS, REVISION AND/OR DEVIATION FROM THIS STANDARD DETAIL. PRINSCO HAS NOT PERFORMED ANY ENGINEERING OR DESIGN SERVICE FOR THIS PROJECT. THE DESIGN ENGINEER SHALL REVIEW THESE DETAILS PRIOR TO CONSTRUCTION TO VERIFY SUITABILITY. © PRINSCO, INC.



1717 16TH ST. NE
WILLMAR, MN 56201
www.prinSCO.com

TITLE: PRO4 24 MOUND DETAIL			
DRAWN BY: BJE	DATE: 30-Apr-26	DRAWING NUMBER:	
SCALE: NTS	SHEET: 1 OF 1	X-#-###	

TYPICAL BED - CROSS SECTION
(NOT TO SCALE)

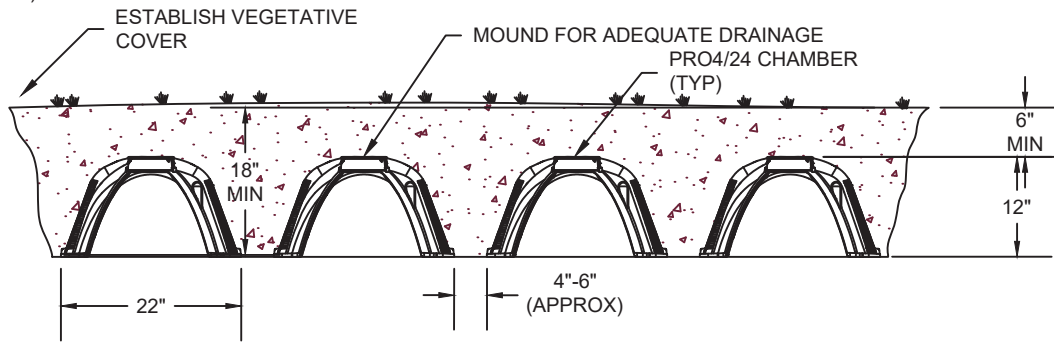

TYPICAL BED - PLAN VIEW
(NOT TO SCALE)

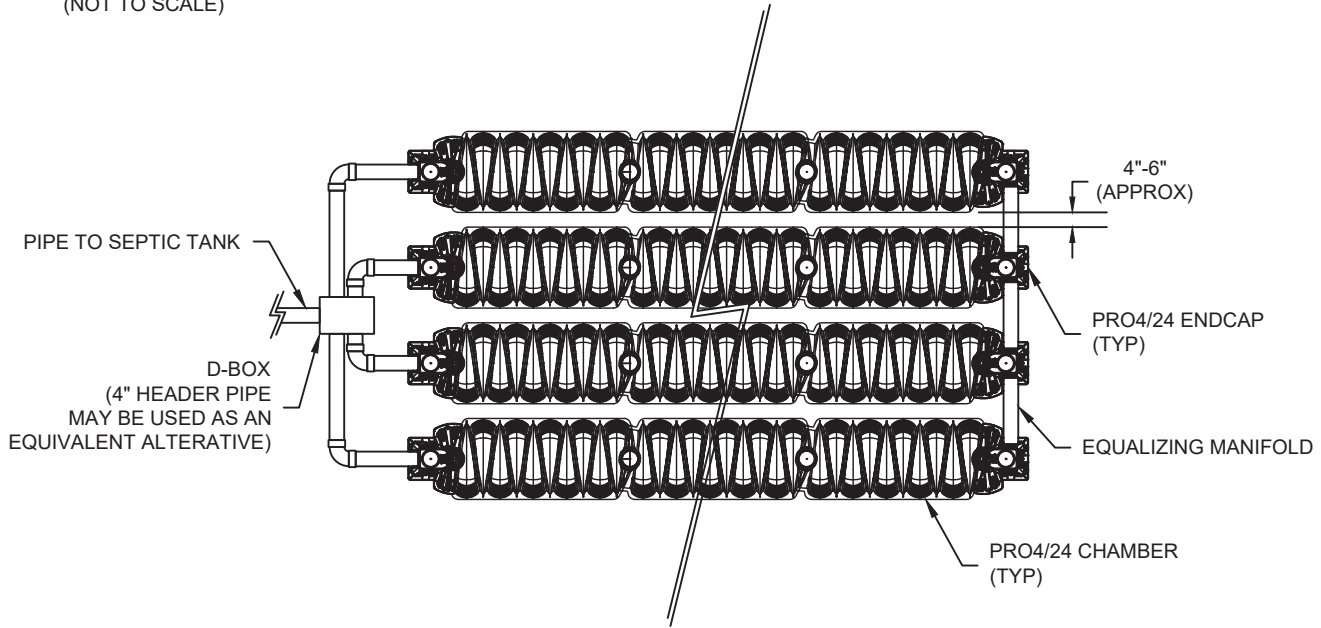

TYPICAL BED - PLAN VIEW
(NOT TO SCALE)

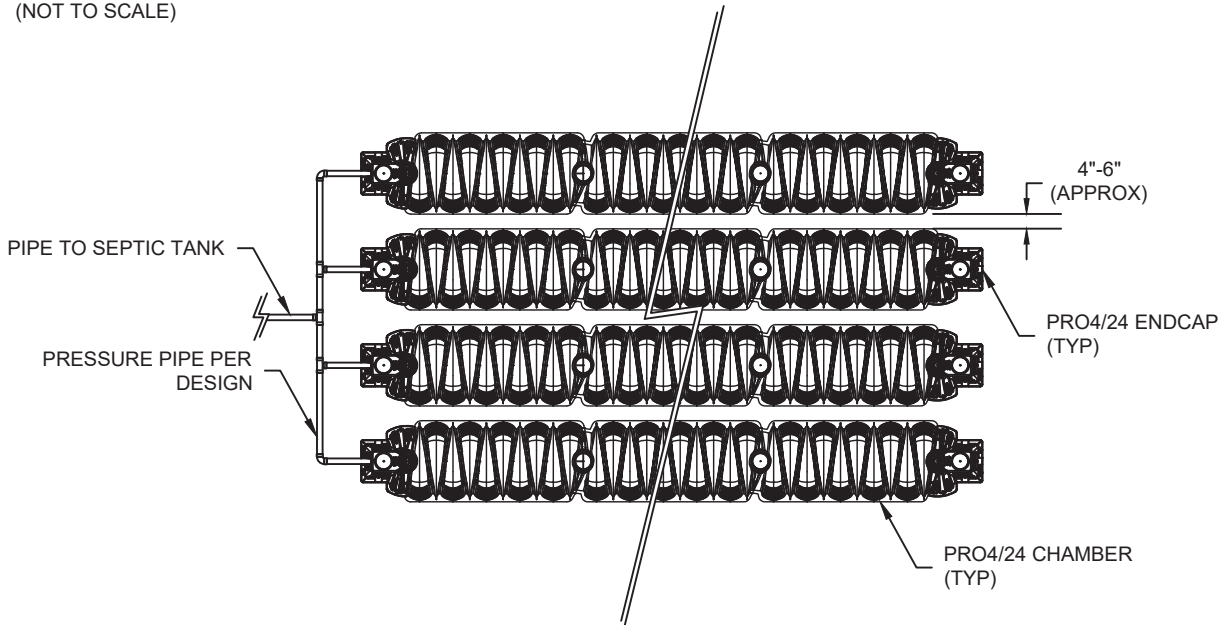

NOTES:

1. LENGTH, DEPTH, AND NUMBER OF CHAMBER ROWS DETERMINED BY DESIGN.
2. CONFIGURATIONS SHOWN APPLY TO GRAVITY, PUMP, DOSING, AND LOW PRESSURE SYSTEM TYPES.

THIS DETAIL DEPICTS RECOMMENDED INSTALLATION PRACTICES AND IS NOT INTENDED TO SUPERSEDE ANY NATIONAL, STATE OR LOCAL SPECIFICATIONS. PRINSCO BEARS NO RESPONSIBILITY FOR ANY ALTERATIONS, REVISION AND/OR DEVIATION FROM THIS STANDARD DETAIL. PRINSCO HAS NOT PERFORMED ANY ENGINEERING OR DESIGN SERVICE FOR THIS PROJECT. THE DESIGN ENGINEER SHALL REVIEW THESE DETAILS PRIOR TO CONSTRUCTION TO VERIFY SUITABILITY. © PRINSCO, INC.



1717 16TH ST. NE
WILLMAR, MN 56201
www.prinSCO.com

TITLE: PRO 24 BED DETAIL			
DRAWN BY: BJE	DATE: 30-Apr-26	DRAWING NUMBER:	
SCALE: NTS	SHEET: 1 OF 1	X-#-###	

Trench Installation

Before you begin the installation, read these instructions and any documents referenced in it. Pro4 chambers may only be installed per State and/or local regulations and, like all drainfields, must have prior site and soil conditions approved. Form DEP 4016 should be obtained before any system is constructed.

Required materials and tools:

- Pro4 Chambers and Endcaps
- PVC pipe and couplings
- Excavating equipment
- Leveling equipment
- Shovel and rake
- Measuring device
- Cordless drill, drill-bits, and hole-saw

Site Preparation (During Installation Only)

Do not install the system when there are wet soil conditions. Install erosion control prior to installation if necessary to protect the site.

Step 1: Establish the location of the system components, including trenches and mark out accordingly. Set the elevations for the system components and chamber system according to plan and per state and local codes. Refer to the minimum trench spacing per state and local codes. Florida trench systems by code are a minimum of 2' spacing between rows.

Step 2: Trenches can be level or have the prescribed fall of no more than 1" per 10' of trench length. Trench widths should be per the following *table to the right*.

Minimum Trench Width Requirements	
Pro4/24	24"

Step 3: Clear any debris within the trench and hand rake the trench bottom. If any bottom or sidewall smearing has occurred, scarify those surfaces.

Step 4: Perform a final elevation check on each trench and system components before installing chambers.

Preparing the Pro4 Endcaps

Use the appropriate Pro4 Endcap Model per Pro4 Chamber Size, see Endcap Specifications.

Step 1: Drill an opening in the endcap with a hole saw where the inlet pipe will be inserted. Select the drill point based upon the invert elevation and hole size. Pro4 Endcaps can accommodate up to 4" Schedule 40 and SDR-35 pipe.

Pro4 Endcap Inlet Drill Locations

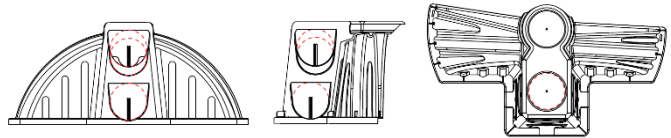

Step 2: Install the splash guard by removing the attached guard from the endcap and inserting the risers of the guard into the channels underneath the endcap footer.

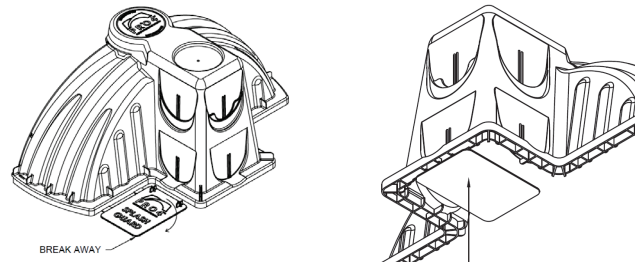

Installing the System / Chamber Assembly

Step 1: Check the elevation of the invert and make sure it is aligned with the header pipe.

Step 2: Position the first chamber within the start of the trench. The end of the chamber marked **INLET** begins the row and should be facing the header pipe.

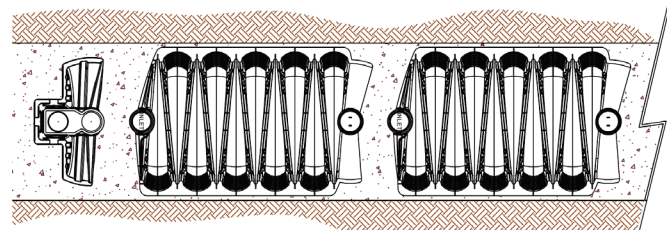

PRO 4[®] Trench Installation Instructions

Step 3: Place the prepared endcap over the chamber and make sure it is aligned with the header pipe. The endcap will snap into place with locking tabs when pressed down on the chamber.

Step 4: With a hole saw, drill appropriate size hole in endcap. Insert the inlet pipe into the prepared opening at least 2" to assure pipe is seated properly.

Step 5: With another chamber, align the coupler end marked **INLET** over the previously placed chamber. Lower the chamber towards the ground. Press down on the center of the chamber until a noticeable "click" is heard to obtain full engagement. The chamber-to-chamber coupler has a positive locking feature designed to keep the chambers secure during backfill.

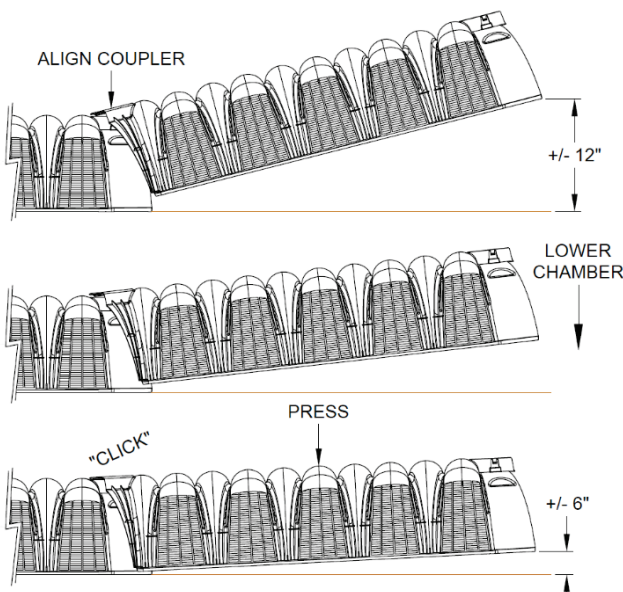

Note: Chambers can be disengaged by lifting the end of chamber away from the connection. Multiple disengagements may cause the locking tabs to break. If this occurs, a screw may be used to connect the chambers. Place screw in the center of the top bowl and make sure screw engages bottom bowl for connection.

Step 6: For installation following contours, rotate the chambers to align with the trench contour. Pro4 chambers joints can rotate a maximum of 10° in both directions.

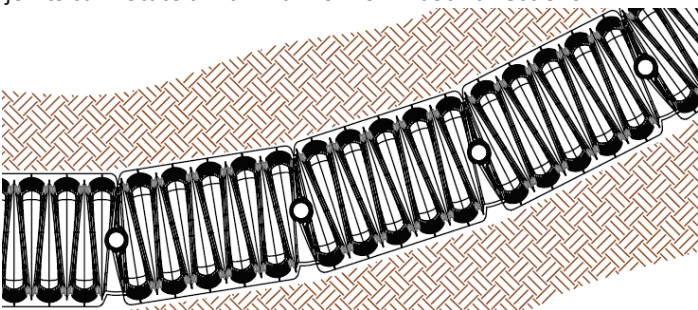

Step 7: Continue installing the chambers until the lateral is complete.

Step 8: Install an endcap on the last chamber in the trench.

Note: PVC pipe may be installed between end caps to create looped ends when necessary per state and local code. Pipe must meet Rule 62-6 F.A.C.

Step 9: Once all the chambers and endcaps are installed in the trench lateral, begin backfilling with soil around the sides of the chamber and around the endcaps by hand. Fill soil just above the top of the sidewall louvers.

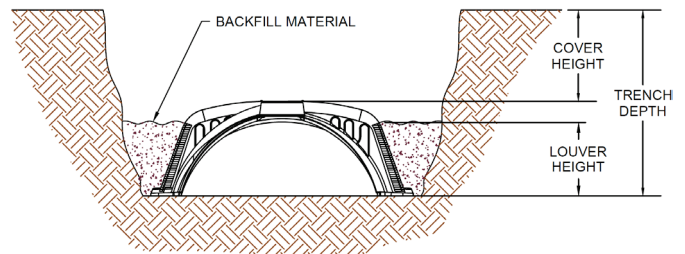

Step 10: Compact this soil by walking along the sides of each chamber.

Note: Walking in the soil is an important step that will keep the chambers from shifting during final backfill and provide the necessary support when covering the system.

Step 11: Follow this process for each trench.

Installing the Optional Inspection Port

Pro4 Chambers are designed to accommodate an optional inspection port at the beginning and end of trench laterals and mid-line at 4-foot intervals.

Step 1: On the marked area on the chamber or endcap, use a hole saw to drill for the inspection port pipe. The top cut-out sections can accommodate up to 4" Schedule 40 pipe.

Step 2: Insert the section of pipe into the cutout port based on the desired method:

Method A: Pipe extends down a few inches, supported by a pipe coupler.

Method B: Pipe extends down to trench bottom with multiple holes at various elevations.

Method A

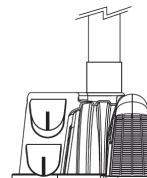

Method B

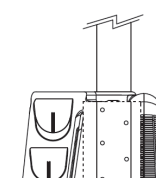

Step 3: Secure the pipe using a screw through the coupler/endcap ring.

Step 4: Fasten either a threaded clean out cap or non-threaded cap to the end of the inspection pipe at the specified length to allow access after covering the system.

Covering the Pro4 Chamber System

State and local codes require that chamber systems be inspected and approved prior to backfilling by a health official or other official with jurisdiction.

Step 1: Begin by backfilling the trenches with soil using a track-hoe or back-hoe.

Note: A minimum 6" of cover is required for non-traffic application. A minimum of 12" of compacted cover is required before a vehicle can drive over the chamber system. This is during installation only. Per Florida Rule no vehicular traffic is allowed once installation is completed.

Step 2: It is recommended to allow for soil settling by adding 3-4 additional inches of soil cover. This additional soil will also help protect against potential erosion.

Step 3: To prevent further erosion, cover the system with seed or sod. Per state and local requirements.

Step 4: For new construction, it is recommended to mark the area around the system to prevent construction vehicles from unknowingly driving over the system.

Covering the System Notes (During Installation Only)

When operating a vehicle near a chamber drain field system, avoid driving directly over the top of the chamber. Pro4 Chambers require a minimum of 12" of compacted cover over the top of chambers before driving over the system. For shallow cover applications installed with 6" of compacted backfill. Mound system with 12" of soil before driving over it, and the grade it back to 6" upon completion. When backfilling and driving over a chamber system, do not travel parallel over the length of the chamber rows, but rather perpendicular. Additional soil compaction may occur if heavy equipment is operated over a system. Do not drive over the system when backfilling with sand.

Prinsco's Pro4 Limited Warranty is available at www.Prinsco.com or call (320) 222-6800.

For questions and technical support: Please contact Prinsco Technical Services at (320) 222-6800 or visit us at www.Prinsco.com.

Scan to watch install tips

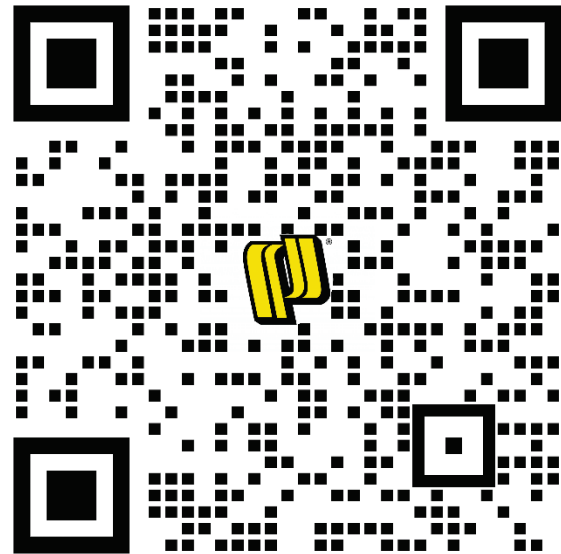

Mound Installation

Before you begin the installation, read these instructions and any documents referenced in it. Pro4 chambers may only be installed per State and/or local regulations and, like all drainfields, must have prior site and soil conditions approved. Form DEP 4016 should be obtained before any system is constructed.

Required materials and tools:

- Pro4 Chambers and Endcaps
- PVC pipe and couplings
- Tracked excavating equipment
- Leveling equipment
- Shovel and rake
- Measuring device
- Cordless drill, drill-bits, and hole-saw

Site Preparation (During Installation Only)

Do not install the system when there are wet soil conditions. Install erosion control prior to installation if necessary to protect the site.

Step 1: Establish the location of the system components, including the mound and mark out accordingly. Set the elevations for the system components and chamber system according to plan and per state and local codes. Refer to the Vehicle Loading section for specified cover requirements. Follow minimum sizing per state and local codes. During installation only. Per Florida Rule, no vehicular traffic is allowed after installation is complete.

Step 2: Remove debris and make sure the mound system base is level or have the prescribed fall of no more than 1" per 10' length.

Step 3: Rake the mound native soil by hand or using the teeth of a backhoe/plow. If any smearing has occurred, scarify those surfaces.

Sand Installation

Sand should meet design specifications for the system.

Step 1: Use a tracked vehicle to spread a minimum 12-inch lift of the specified fill material over the prepared area.

Note: It is critical to compact the fill to prevent settling.

Step 2: Using a tracked vehicle or vibratory plate, evenly compact the sand by using the tracks to drive across the sand bed. Keep making passes until all sand is compacted.

Note: The compaction of each sand lift must meet a standard proctor density of 90%. Add water to bring moisture content to 10% to aid in compaction.

Step 3: Install consecutive lifts using steps 1 and 2 to complete design. Each lift should not exceed a 12-inch height.

Step 4: Once design height is met, use a hand rake to scarify the top surface of sand. Measure final elevation to meet design.

Step 5: Install chamber system per instructions.

Preparing the Pro4 Endcaps

Use the appropriate Pro4 Endcap Model per Pro4 Chamber Size, see Endcap Specifications.

Step 1: Drill an opening in the endcap with a hole saw where the inlet pipe will be inserted. Select the drill point based upon the invert elevation and hole size. Pro4 Endcaps can accommodate up to 4" Schedule 40 and SDR-35 pipe.

Pro4 Endcap Inlet Drill Locations

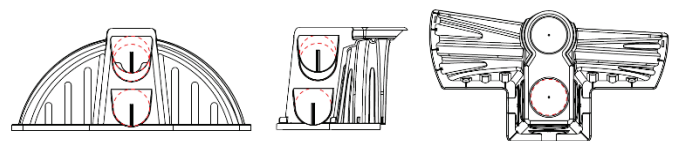

Step 2: Install the splash guard by removing the attached guard from the endcap and inserting the risers of the guard into the channels underneath the endcap footer.

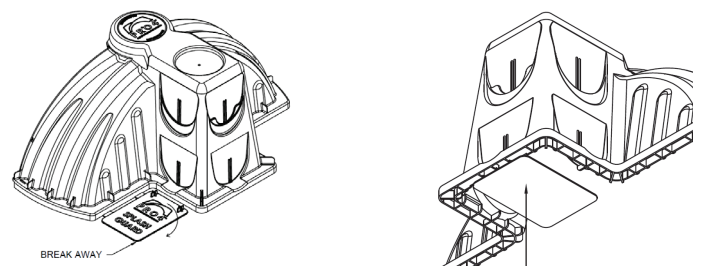

Installing the System / Chamber Assembly

Step 1: Check the elevation of the invert and make sure it is aligned with the header pipe.

Step 2: Position the first chamber within the start of the trench. The end of the chamber marked **INLET** begins the row and should be facing the header pipe.

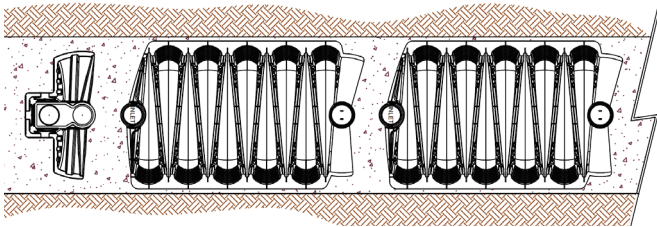

Step 3: With another chamber, place the coupler end marked **INLET** over the previously placed chamber. Lower the chamber towards the ground. Press down on the center of the chamber until a noticeable “click” is heard to obtain full engagement. The chamber-to-chamber coupler has a positive locking feature designed to keep the chambers secure during backfill.

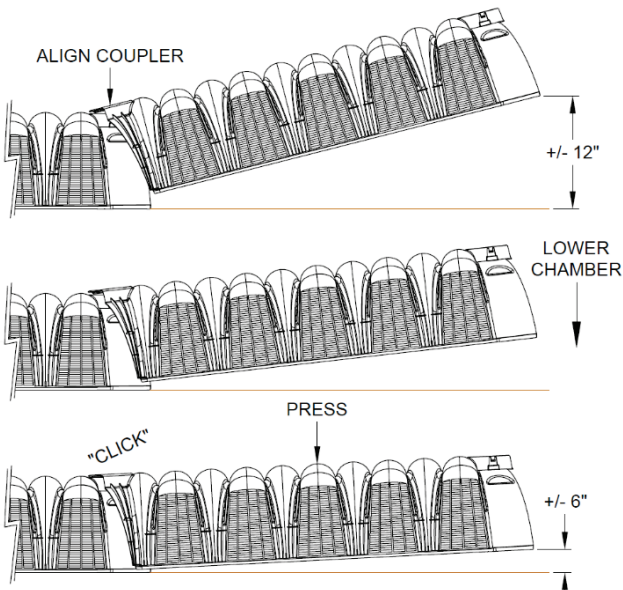

Note: Chambers can be disengaged by lifting the end of chamber away from the connection. Multiple disengagements may cause the locking tabs to break. If this occurs a screw can be used to connect the chambers. Place screw into center of top bowl and assure screw engages bottom bowl for connection.

Step 7: Continue installing the chambers until the lateral is complete.

Step 8: Install an endcap on the last chamber in the trench. may be used to connect the chambers.

Note: Straight pipe may be installed between end caps to create looped ends when necessary per state and local code.

Step 9: Once all the chambers and endcaps are installed, begin backfilling with sand around the sides of each chamber and around the endcaps. Fill sand just above the top of the sidewall louvers.

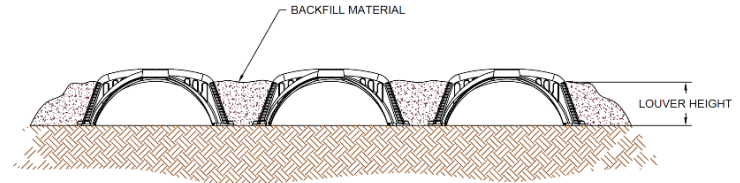

Step 9: Compact this sand by walking along the sides of each chamber.

Note: Walking in the soil is an important step that will keep the chambers from shifting during final backfill and provide the necessary support when covering the system.

Installing the Optional Inspection Port

Pro4 Chambers are designed to accommodate an optional inspection port at the beginning and end of trench laterals and mid-line at 4-foot intervals.

Step 1: On the marked area on the chamber or endcap, use a hole saw to drill for inspection port pipe. The top cut-out sections can accommodate up to 4" Schedule 40 pipe.

Step 2: Insert the section of pipe into the cutout port based on the desired method:

Method A: Pipe extends down only a few inches, supported by a pipe coupler.

Method B: Pipe rests on the lip of the chamber.

Method A

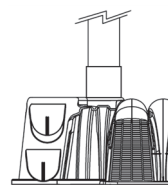

Method B

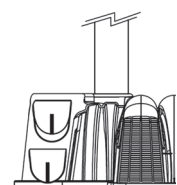

Step 3: Secure the pipe using a screw thru the coupler ring.

Step 4: Fasten either a threaded clean out cap or non-threaded cap to the of the inspection pipe at the specified length to allow access after covering the system.

Covering the Pro4 Chamber System (During Installation Only)

State and local codes require that chamber systems be inspected and approved prior to backfilling by a health official or other official with jurisdiction.

Step 1: Begin by backfilling the trenches with soil using a track-hoe or back-hoe.

Note: A minimum 6" of cover is required for non-traffic application. A minimum of 12" of compacted cover is required before a vehicle can drive over the chamber system. During installation only. Per Florida Rule, no vehicular traffic is allowed once installation is complete.

Step 2: It is recommended to allow for soil settling by adding 3-4 additional inches of soil cover. This additional soil will also help protect against potential erosion.

Step 3: To prevent further erosion, cover the system with seed or sod. Per state and local requirements if needed.

Step 4: For new construction, it is recommended to mark the area around the system to prevent construction vehicles from unknowingly driving over the system.

Covering the System Notes (During Installation Only)

When operating a vehicle near a chamber drain field system, avoid driving directly over the top of the chamber. Pro4 Chambers require a minimum of 12" of compacted cover over the top of chambers before driving over the system. For shallow cover applications installed with 6" of compacted backfill. Mound system with 12" of soil before driving over it, and the grade it back to 6" upon completion. When backfilling and driving over a chamber system, do not travel parallel over the length of the chamber rows, but rather perpendicular. Additional soil compaction may occur if heavy equipment is operated over a system. Do not drive over the system when backfilling with sand.

Prinsco's Pro4 Limited Warranty is available at www.Prinsco.com or call (320) 222-6800.

For questions and technical support: Please contact Prinsco Technical Services at (320) 222-6800 or visit us at www.Prinsco.com.

Scan to watch install tips

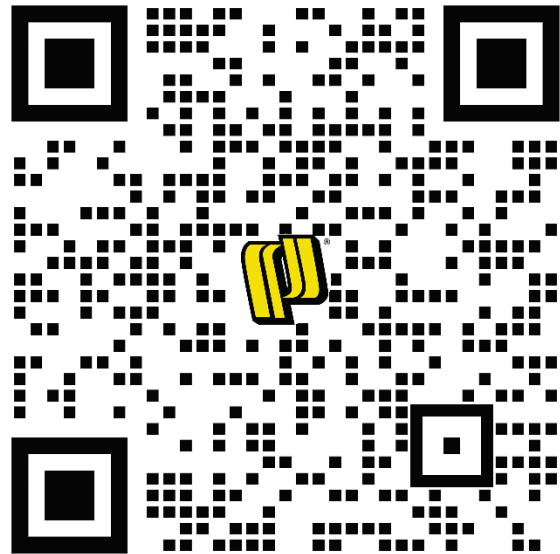

Bed Installation

Before you begin the installation, read these instructions and any documents referenced in it. Pro4 chambers may only be installed per State and/or local regulations and, like all drainfields, must have prior site and soil conditions approved. Form DEP 4016 should be obtained before any system is constructed.

Required materials and tools:

- Pro4 Chambers and Endcaps
- PVC pipe and couplings
- Excavating equipment
- Leveling equipment
- Shovel and rake
- Measuring device
- Cordless drill, drill-bits, and hole-saw

Site Preparation (During Installation Only)

Do not install the system when there are wet soil conditions. Install erosion control prior to installation if necessary to protect the site.

Step 1: Establish the location of the system components, including the bed and mark out accordingly. Set the elevations for the system components and chamber system according to plan and per state and local codes. Refer to the Vehicle Loading section for specified cover requirements. During Installation Only, per Florida Rule no vehicular traffic is allowed after installation is complete.

Step 2: Remove debris and make sure the mound system base is level or have the prescribed fall of no more than 1" per 10' length.

Step 3: Clear any debris within the installation area and hand rake the bed's base. If any base or sidewall smearing has occurred, scarify those surfaces.

Step 4: Perform a final elevation check on the bed and system components before installing chambers.

Preparing the Pro4 Endcaps

Use the appropriate Pro4 Endcap Model per Pro4 Chamber Size, see Endcap Specifications.

Step 1: Drill an opening in the endcap with a hole saw where the inlet pipe will be inserted. Select the drill point based upon the invert elevation and hole size. Pro4 Endcaps can accommodate up to 4" Schedule 40 and SDR-35 pipe.

Pro4 Endcap Inlet Drill Locations

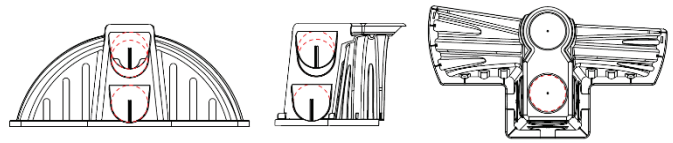

Step 2: Install the splash plate by removing the guard from the endcap and inserting the risers of the guard into the channels underneath the endcap footer.

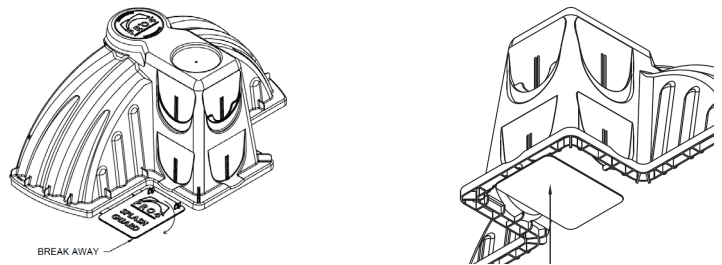

Installing the System / Chamber Assembly

Step 1: Check the elevation of the invert and make sure it is aligned with the header pipe.

Step 2: Position the first chamber within the start of the bed. The end of the chamber marked **INLET** begins the row and should be facing the header pipe.

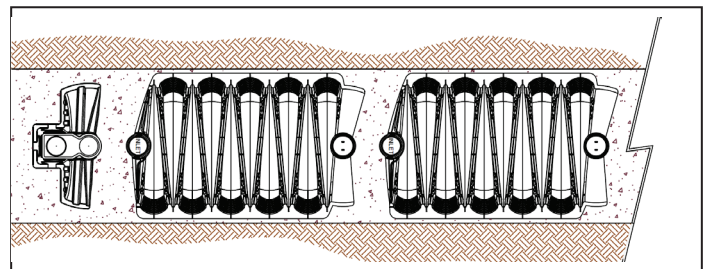

Step 3: Place the prepared endcap over the chamber and make sure it is aligned with the header pipe. The endcap will snap into place with locking tabs when pressed down on the chamber.

Step 4: Insert the inlet pipe into the prepared endcap opening. The pipe should be inserted at least 2" to assure the pipe is seated properly.

Step 5: With another chamber, align the coupler end marked **INLET** over the previously placed chamber. Lower the chamber towards the ground. Press down on the center of the chamber until a noticeable “click” is heard to obtain full engagement. The chamber-to-chamber coupler has a positive locking feature designed to keep the chambers secure during backfill.

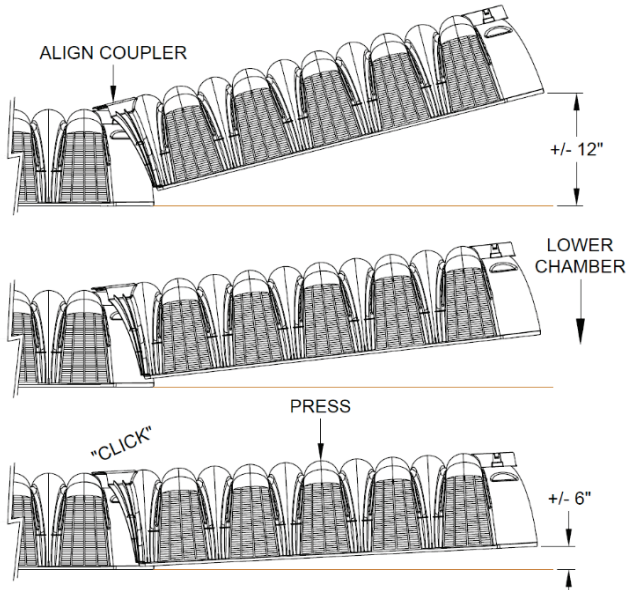

Note: Chambers can be disengaged by lifting the end of chamber away from the connection. Multiple disengagements may cause the locking tabs to break. If this occurs, a screw may be used to connect the chambers. Place screw into center of top bowl and assure screw engages bottom bowl for connection.

Step 6: For installations following contours, rotate the chambers to align with the bed contour. Pro4 chambers joints can rotate a maximum of 10° in both directions.

Step 7: Continue installing the chambers until the lateral is complete.

Step 8: Install an endcap on the last chamber in the lateral.

Step 9: Follow this process for each lateral in the bed.

Note: It is recommended that chambers in bed systems have 6” spacing between rows. Follow local and state codes regarding chamber spacing.

Step 10: Once all the chambers and endcaps are installed in the bed, begin carefully backfilling with soil around the sides of the chamber and around the endcaps. Fill soil just above the top of the sidewall louvers.

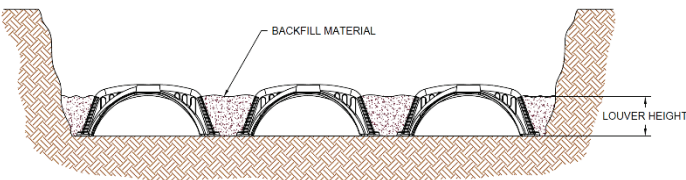

Step 11: Compact this soil by walking along the sides of each chamber.

Note: Walking in the soil is an important step that will keep the chambers from shifting during final backfill and provide the necessary support when covering the system.

Installing the Optional Inspection Port

Pro4 Chambers are designed to accommodate an optional inspection port at the beginning and end of trench laterals and mid-line at 4-foot intervals.

Step 1: On the marked area on the chamber or endcap, use a hole saw to drill for the inspection port pipe. The top cut-out sections can accommodate up to 4” Schedule 40 pipe.

Step 2: Insert the section of pipe into the cutout port based on the desired method:

Method A: Pipe extends down a few inches, supported by a pipe coupler.

Method B: Pipe extends down to trench bottom with multiple holes at various elevations.

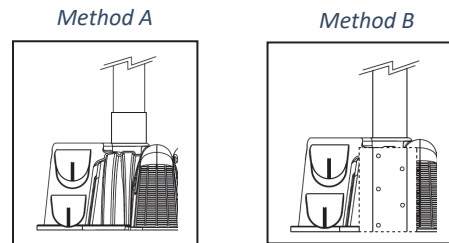

Step 3: Secure the pipe using a screw thru the coupler ring.

Step 4: Fasten either a threaded clean out cap or non-threaded cap to the end of the inspection pipe at the specified length to allow access after covering the system.

Covering the Pro4 Bed Chamber System (During Installation Only). State and local codes require that chamber systems be inspected and approved prior to backfilling by a health official or other official with jurisdiction.

Step 1: Begin by backfilling the bed with soil using a track-hoe or back-hoe.

Note: Do not drive wheeled vehicles over the bed system when applying backfill.

Note: A minimum 6” of cover is required for non-traffic application. A minimum of 12” of compacted cover is required before a vehicle can drive over the chamber system. Refer to Vehicle Loading for requirements found below in this document. Pro4 chamber bed applications allow for a maximum of 4' of cover. **Note:** Florida rule does not allow for the bottom of the drainfield to be more than 30” below ground surface in new systems. Follow rule 62-6 for requirements for the depth of the bottom of the drainfield from ground surface.

Step 2: It is recommended to allow for soil settling by adding 3-4 additional inches soil the system. This additional soil will also help protect against potential erosion.

Step 3: To prevent further erosion, cover the system with seed or sod.

Step 4: For new construction, it is recommended to mark the area around the system to prevent construction vehicles from unknowingly driving over the system.

Vehicle Loading (During Installation Only)

When operating a vehicle near a chamber drain field, avoid driving directly over the top of the chamber. It is recommended to mound 12" of soil over the bed system before driving over it and grade the cover to 6" upon completion. When backfilling and driving over a chamber system, do not travel parallel over the length of chamber rows, but rather perpendicular. Additional soil compaction may occur if heavy equipment is operated over a system. Do not drive over the system when backfilling with sand.

Prinsco's Pro4 Limited Warranty is available at www.Prinsco.com or call (320) 222-6800.

For questions and technical support: Please contact Prinsco Technical Services at (320) 222-6800 or visit us at www.Prinsco.com.

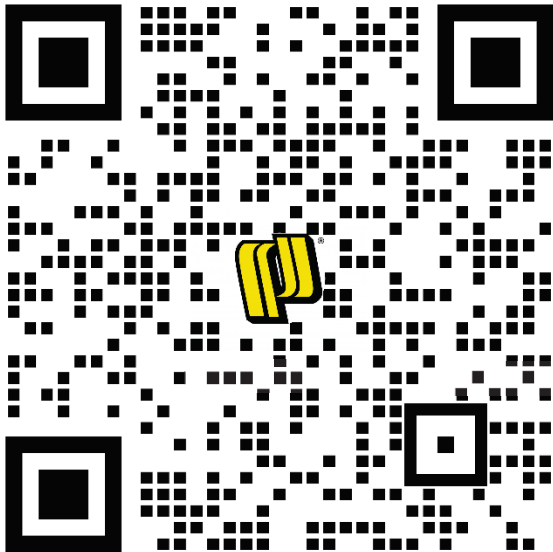

[Scan to watch install tips](#)

Pressure Distribution Installation

Before you begin the installation, read these instructions and any documents referenced in it. Pro4 chambers may only be installed per State and/or local regulations and, like all drainfields, must have prior site and soil conditions approved. Contact your local health department if the chamber installation requirements need clarification.

Required materials and tools:

- Pro4 Chambers and Endcaps
- PVC pipe and couplings
- Excavating equipment
- Leveling equipment
- Shovel and rake
- Measuring device
- Cordless drill, drill-bits, and hole-saw

Site Preparation (During Installation Only)

Do not install the system when there are wet soil conditions. Install erosion control prior to installation if necessary to protect the site.

Step 1: Establish the location of the system components, including trenches and mark out accordingly. Set the elevations for the system components and chamber system according to plan and per state and local codes. Refer to the Vehicle Loading section for specified cover requirements. Follow minimum trench spacing per state and local codes. Per Florida rule, no vehicular traffic is allowed after installation is complete.

Step 2: Place pressure lateral pipe on the ground for each chamber row.

Note: Follow local and state pressure distribution regulations when preparing the pipe.

Step 3: Drill pressure pipe orifices per plan (diameter and spacing). Orifices should be located at the top of the pipe.

Step 4: Drill a drain hole at the end of the pressure lateral on the bottom to allow for pipe drainage after each dose. Drain holes should be above the splash plate to prevent erosion.

Note: A pressure test (squirt test) may be required by the local health department prior to chamber installation.

Preparing the Pro4 Endcaps

Use the appropriate Pro4 Endcap Model per Pro4 Chamber Size, see Endcap Specifications.

Step 1: Drill an opening in the endcap at the elevation where the pressure pipe will run. The endcap can accommodate up to 2" Schedule 40 pipe.

Note: The pressure pipe lateral can be installed using pipe hanging ties near the ceiling of chamber or installed with the pipe lateral resting on the trench or bed surface.

Pro4 Endcap Pressure Pipe Drill Location

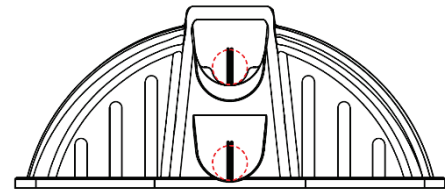

Step 2: Install the splash guard by removing the guard from the endcap and inserting the risers of the guard into the channels underneath the endcap.

Note: The splash guard shall be installed at the end of the pressure lateral. Drill a hole in the pressure lateral at the end of the pipe on the bottom of the pipe to allow laterals to drain. Install splash guard under drain hole.

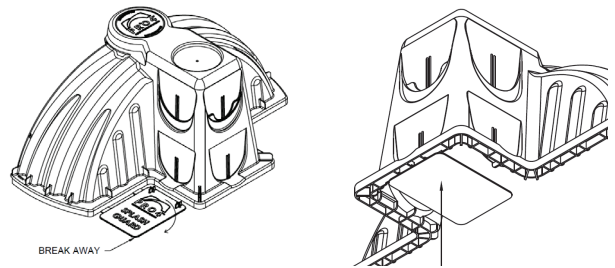

Step 3: Insert the pressure lateral pipe through the drilled endcap hole, connect the lateral pipe to the manifold pipe.

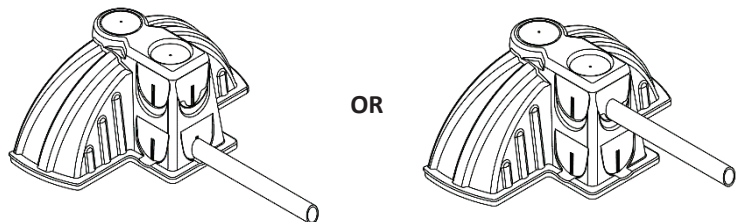

Installing the System / Chamber Assembly

Step 1: Position the first chamber within the start of the trench. The end of the chamber marked **INLET** begins the row and should be facing the header pipe.

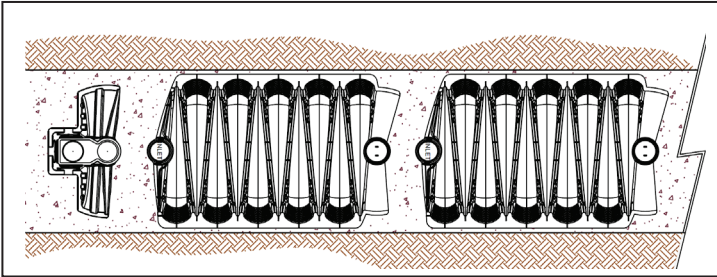

Step 2: Move the prepared endcap along the pressure lateral pipe and over the chamber coupler. The endcap will snap into place with locking tabs when pressed down on the chamber.

Step 3: With another chamber, place the coupler end marked **INLET** over the previously placed chamber. Lower the chamber towards the ground. Press down on the center of the chamber until a noticeable “click” is heard to obtain full engagement. The chamber-to-chamber coupler has a positive locking feature designed to keep the chambers secure during backfill.

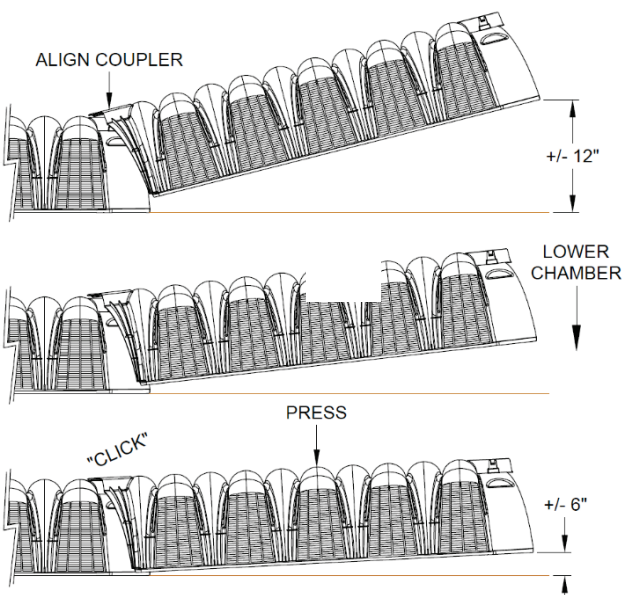

Note: Chambers can be disengaged by lifting the end of chamber away from the connection. Multiple disengagements may cause the locking tabs to break. If this occurs, a screw may be used to connect the chambers. Place screw into center of top bowl and assure screw engages bottom bowl for connection.

Step 4A (Pipe on trench or bed bottom): Where regulation allows, pipe is recommended to lay on the bottom of the trench or bed. Stabilize the pipe with cross tees or other method to prevent movement.

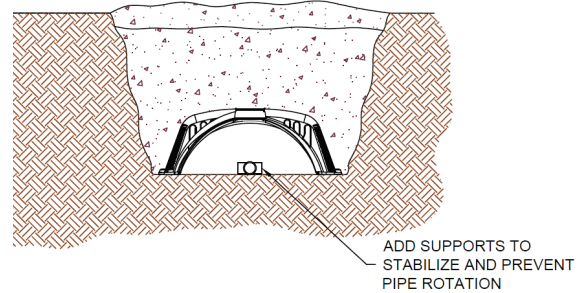

Step 4B (Hanging the pressure pipe): Using plastic pipe hanging ties, fasten the pressure pipe to the ceiling of the chamber at back end using the drain hole slots on the coupler.

Hanging Tie Recommendations

Step A

- Feed the hanging tie from underneath the chamber so that the tie connection leaves space between the two couplers.
- Use a finger or spacer to leave a 3/4"-1" gap between the pipe and coupler bowl.
- Tighten the hanging tie so that the pressure pipe is level with the underside of the chamber.
- **NOTE: OVER TIGHTENING THE HANGING TIE MAY DEFORM THE TOP BOWL AND DISRUPT CHAMBER CONNECTION.**

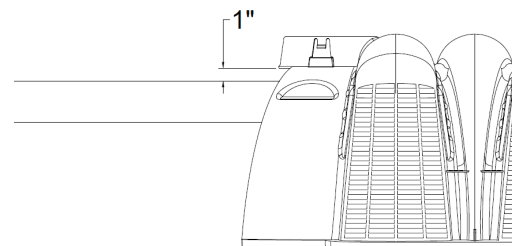

Step B

- Prior to connecting to the next chamber, place a Pro4 Chamber or Endcap 8'-12' down the line from the last tied connection.
- Rest the pressure pipe on the Pro4 Chamber or Endcap so it can be supported above the sand bed. This takes the pressure off the pipe tie and eliminates potential bowl deflection.
- Connect the next Pro4 Chamber by standard connection method.

Repeat steps A & B

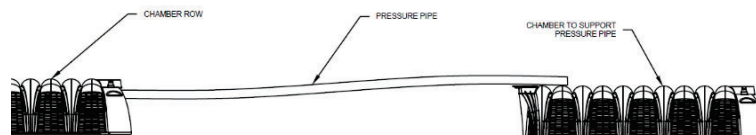

Aligning chambers in bed

- Sand fill should be leveled and compacted with boots at the feet of the chamber connection so that sand does not interfere between Chamber feet.

Step 5: For installation following contours, rotate the chambers to align with the trench contour. Pro4 chamber joints can rotate a maximum of 10° in both directions.

Step 6: Continue installing the chambers until the lateral is complete.

Step 7: Install an endcap on the last chamber in the trench. If the pressure pipe is hanging, do not use a hanging tie on the last chamber; rather let the endcap support the pipe. It is recommended to install a clean-out for drainfield maintenance and flushing at the end of each lateral.

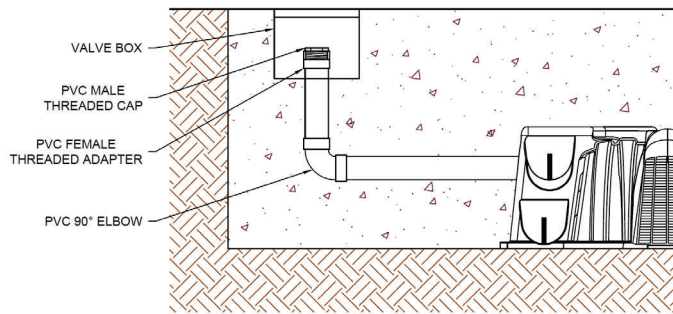

Step 8: Once all the chambers and endcaps are installed in a trench lateral, begin backfilling with soil around the sides of the chamber and around the endcaps. Fill soil just above the top of the sidewall louvers.

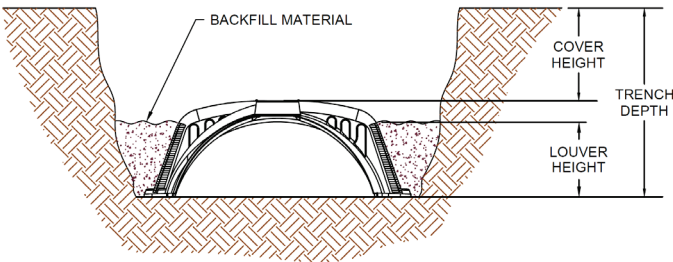

Step 9: Compact this soil by walking along the sides of each chamber.

Note: Walking in the soil is an important step that will keep the chambers from shifting during final backfill and provide the necessary support when covering the system.

Step 10: Follow this process for each trench.

Installing the Optional Inspection Port

Pro4 Chambers are designed to accommodate an optional inspection port at the beginning and end of trench laterals and mid-line at 4-foot intervals.

Step 1: On the marked area on the chamber or endcap, use a hole saw to drill for inspection port pipe. The top cut-out sections can accommodate up to 4" Schedule 40 pipe.

Step 2: Insert the section of pipe into the cutout port based on the desired method:

Method: Pipe extends down only a few inches; supported by a pipe coupler.

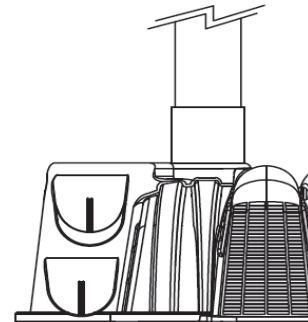

Prinsco's Pro4 Limited Warranty is available at www.Prinsco.com or call (320) 222-6800.

For questions and technical support: Please contact Prinsco Technical Services at (320) 222-6800 or visit us at www.Prinsco.com.

Scan to watch install tips

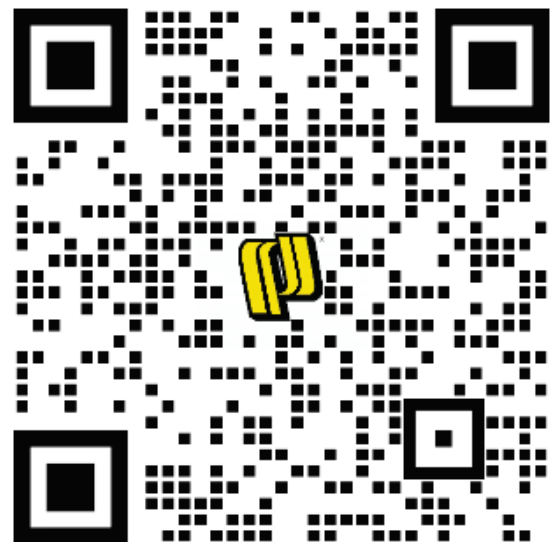

TYPICAL 90-DEGREE BEND - PROFILE VIEW
(NOT TO SCALE)

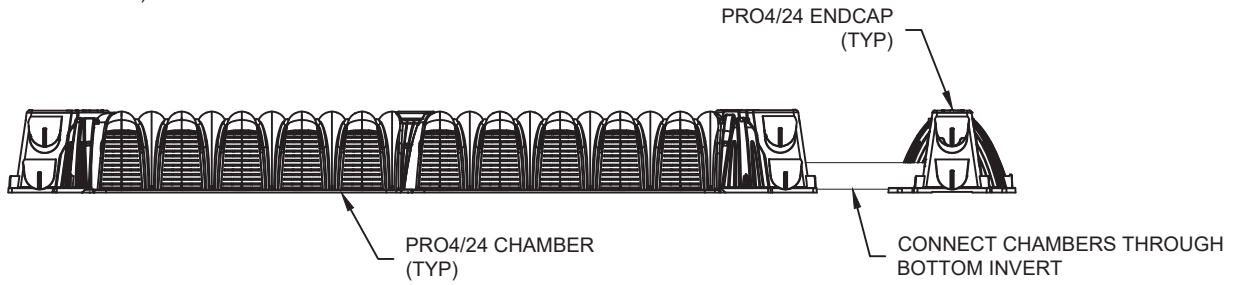

TYPICAL 90-DEGREE BEND - PLAN VIEW
(NOT TO SCALE)

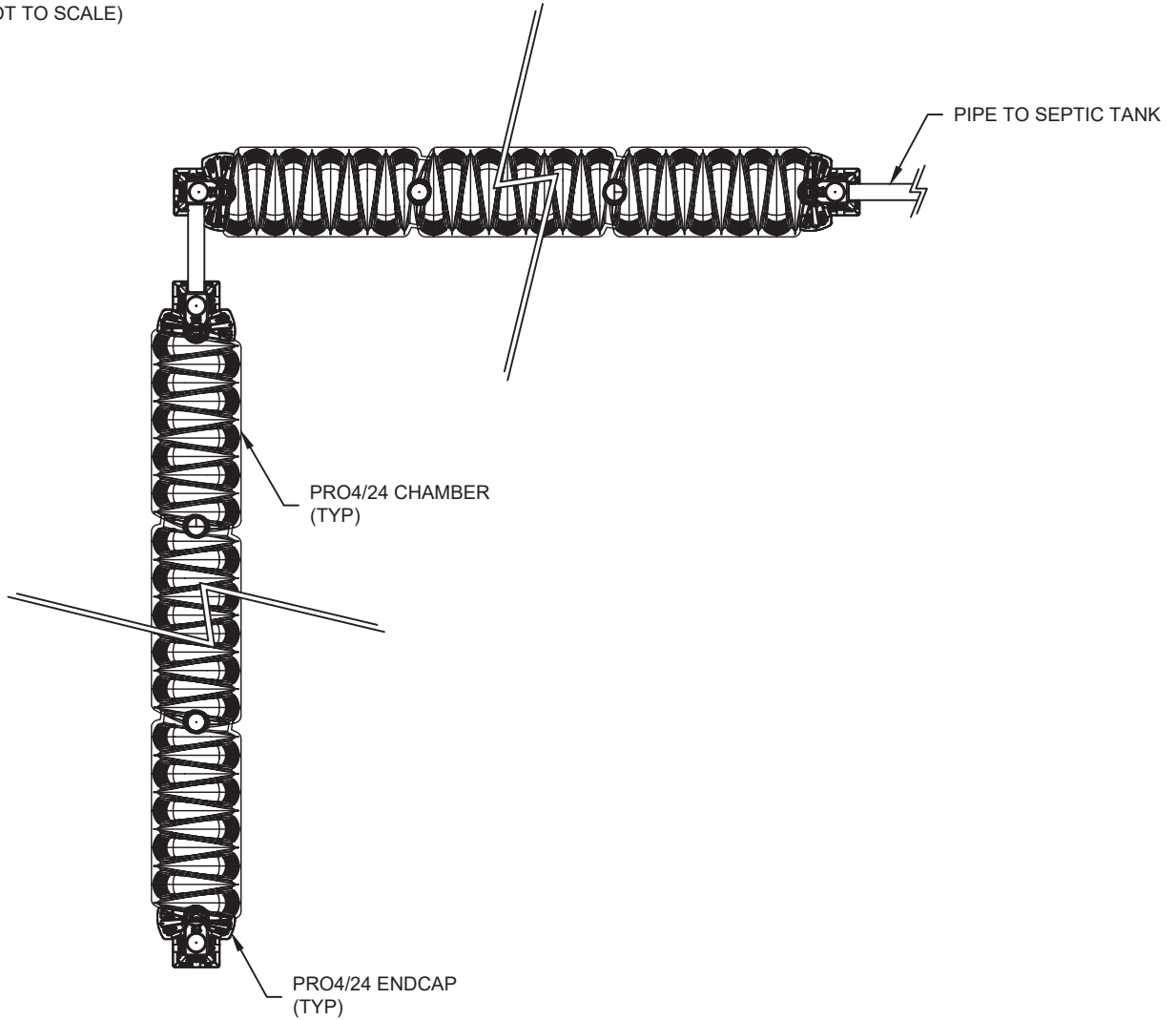

NOTES:

1. LENGTH, DEPTH, AND NUMBER OF TRENCHES DETERMINED BY DESIGN.

THIS DETAIL DEPICTS RECOMMENDED INSTALLATION PRACTICES AND IS NOT INTENDED TO SUPERSEDE ANY NATIONAL, STATE OR LOCAL SPECIFICATIONS. PRINSCO BEARS NO RESPONSIBILITY FOR ANY ALTERATIONS, REVISION AND/OR DEVIATION FROM THIS STANDARD DETAIL. PRINSCO HAS NOT PERFORMED ANY ENGINEERING OR DESIGN SERVICE FOR THIS PROJECT. THE DESIGN ENGINEER SHALL REVIEW THESE DETAILS PRIOR TO CONSTRUCTION TO VERIFY SUITABILITY. © PRINSCO, INC.



1717 16TH ST. NE
WILLMAR, MN 56201
www.prinsco.com

TITLE: PRO4 90 DEGREE BEND DETAIL		
DRAWN BY: RMA	DATE: 20-May-24	DRAWING NUMBER:
SCALE: NTS	SHEET: 1 OF 1	X-#-###

INSTALLING FILTER FABRIC

When installing chambers in uncompacted, well sorted, fine and very fine sands it is recommended by Prinsco Inc. to install filter fabric. Prinsco also recommends filter fabric to be installed if the below conditions are present. The use of filter fabric does not void Prinsco's standard warranty.

- * Installations left uncovered for extended periods of time.
- * Drainfield area not sodded immediately after final cover up.
- * Drainfield located in area where infiltrative surface is less than 24" above seasonal high water table.

Filter Fabric Specifications:

- * Fabric shall be non-woven
- * Weight: .35 oz./s.y to 1 oz./s.y
- * Apparent Opening Size: 20-30 US Sieve (ASTM D 4571)

Note: When installing filter fabric, the filter fabric must be placed so sidewall is completely covered.

Homeowner's Guide

Caring for your Pro4 Septic Chamber system

Three Main Components

- Household Plumbing – functions to; transport used wastewater to septic system.
- Septic Tank – functions to; separate liquids & solids, primary bacterial treatment of organic solids, stores solids until removal by pumping, delivers liquids to soil treatment field.
- Soil Treatment System – functions to; remove bacteria and viruses, reduces nitrogen & phosphorus, and recycles water into ground.

Care & Best Management Practices

Household Plumbing:

- Limit water use -repair any leaks, use low-water-use appliances and fixtures
- Spread water use throughout the day & week
- Minimize the use of harsh cleaners & detergents
- Keep grease, medications, chemicals, and feminine hygiene products out of your system

Septic Tank:

- Pump solids from tank a minimum of every 5-years or when solids build up
- Inspect baffles and/or effluent filters at time of cleaning
- Install & insulate manhole risers to grade for safe access
- Keep lids closed and secure
- Do not use septic tank additives

Soil Treatment System (Pro4 Chambers):

- Maintain good vegetative cover over system for evapotranspiration
- Keep vehicle traffic off system
- Do not plant trees over system area
- Keep roof drains and other rainwater drainage away from tank & drainfield
- Help prevent system freezing:
 - Inspect pipe covers each Fall,
 - Maintain normal daily use over the winter,
 - If you are gone for extended periods, arrange for some water use, or have your tank pumped.

Find more information on the web at:

<https://www.epa.gov/septic/how-care-your-septic-system>

Florida Limited Warranty - Two Year

PRINSCO, INC

TERMS AND CONDITIONS OF SALE AND

STATEMENT OF LIMITED WARRANTY

1. **LIMITED WARRANTY AND LIMITATION OF LIABILITY.** Prinsco warrants to the original purchaser ("Holder"), that our products conform only to the applicable national standards as listed in Prinsco's publicly available corresponding product specifications documents, and are free from defects in materials and workmanship under normal use and service. Improper installation or use and/or any unauthorized repair, modification or alteration of our products will void this warranty. Prinsco gives no warranty and makes no guarantee of the results to be obtained from the use of our products (this includes no assurances of performance). For uninstalled product, this warranty shall be effective only if Prinsco receives notice from the Holder, in writing, of a claim within fifteen (15) days after the defect was or should have been discovered and within one (1) year from the date of our shipment of the product. For installed product, this warranty shall be effective only if Prinsco receives notice from the Holder, in writing, of a claim within thirty (30) days after the defect was or should have been discovered and within two (2) years from the date of our shipment of the product. In addition to the foregoing notice requirements for installed product, this warranty shall not be effective unless Prinsco is given a timely and reasonable opportunity to review the installed product as installed and prior to any removal and/or repair. A review may be requested by contacting Prinsco, during normal business hours, at 1-800-992-1725.

This warranty shall be effective only if the products are installed as required for all site conditions and in accordance with state and local codes, applicable product or industry specification and guidelines, Prinsco's installation recommendations, and other applicable laws. Specifically excluded from this Limited Warranty are product damages resulting from ordinary wear and tear, unauthorized repairs or modifications, misuse, abuse, neglect, or any other damage not caused by Prinsco.

Prinsco's liability under this agreement or otherwise is limited to, at Prinsco's sole election, repair or replacement of the product as to which a claim has been properly made, or refund, in an amount not to exceed the original purchase price. Our selection of one of these alternatives shall be Buyer's exclusive remedy. **IN NO CASE WILL WE BE LIABLE FOR ANY CONSEQUENTIAL DAMAGES, REMOVAL OR INSTALLATION COSTS, DOWNTIME, DAMAGE TO OTHER PROPERTY, LOSS OF BUSINESS OR PROFITS, OR ANY OTHER CONSEQUENTIAL, INCIDENTAL OR SPECIAL DAMAGES EVEN IF WE HAVE BEEN ADVISED OF THE POSSIBILITY OF SUCH DAMAGES.**

THIS LIMITED WARRANTY SET FORTH HERIN IS IN LIEU OF ALL OTHER WARRANTIES EXPRESSED OR IMPLIED. PRINSCO EXPRESSLY EXCLUDES ALL WARRANTIES OTHER THAN THIS LIMITED WARRANTY, INCLUDING ALL IMPLIED WARRANTIES OF MERCHANTABILITY AND FITNESS FOR PARTICULAR PURPOSE OR USE. THE PROVISIONS SET FORTH HEREIN AND ON THE FACE HEREOF CONSTITUTE ALL THE TERMS AND CONDITIONS OF OUR CONTRACT OF SALE AND APPLICABLE LIMITED WARRANTIES.

2. **HANDLING AND USE OF PRODUCTS.** Even if Prinsco offers directions, recommendations or suggestions for the use of our products, it is solely Buyer's responsibility to determine whether a product is suited for the specific needs of Buyer, and there are no representations or warranties except as set forth herein. Buyer assumes all risks and liabilities arising from unloading, discharge, storage, handling, installation, and use of our products, including use of such products as part of or in connection with other equipment. Buyer assumes full responsibility for compliance with all governmental laws, rules and regulations governing unloading, discharge, storage, handling, installation and use of our products. Buyer agrees to indemnify Prinsco, our agents and employees for any and all claims, liabilities and expenses arising out of or caused by the failure of Buyer, its agents or employees to comply with the terms set forth herein or to follow instructions, warnings or recommendations furnished by us in connection with any products delivered to Buyer under this agreement.

3. **CHOICE OF LAW.** This agreement and the transactions contemplated hereby shall be governed in all respects by the laws of the State of Minnesota, without reference to its choice of law principles.

4. **ARBITRATION.** Any controversy or claim arising out of or relating to the limited warranty provided herein, or any alleged breach thereof, shall be settled exclusively by arbitration in accordance with the Rules of the American Arbitration Association, and judgment upon the award rendered by the arbitrator may be entered in any court having jurisdiction thereof. The arbitration shall be conducted in Minneapolis, MN, or at such other place as the parties may agree, by one arbitrator independent of the parties appointed by them by mutual agreement or by the President of the American Arbitration Association.

5. **PRICE DISPUTES.** Any disputes regarding the sale prices of our products charged to Buyer must be submitted, in writing, within thirty (30) calendar days of the date of delivery. Absent such written notice of a price dispute, Buyer agrees to pay the price(s) quoted on the Invoice.

6. **PERMISSIBLE VARIATIONS.** Variation in Product components, dimensions, quantity, appearance, and the like shall be permissible and shall not constitute cause for Buyer's rejection as long as the variations fall within the applicable AASHTO and/or ASTM product specifications at the time of manufacture.

7. **INSPECTION AND REJECTION.** Claims by Buyer regarding incorrect size, type, quantity, shipping damage of delivered product must be presented to Prinsco within fifteen (15) days following the date of receipt of such non-conforming or damage product by Buyer. The absence of any such claim shall constitute unqualified acceptance and a waiver by Buyer of any and all claims related to incorrect size, type, quantities, or shipping damage. No claim of any kind, whether as to delivered or non-delivery of products, and whether or not based on negligence or other tort, shall be greater in amount than the purchase price of such nonconforming, damaged, or undelivered products.

8. **RETURNS/RESTOCKING CHARGES.** Prinsco reserves the right to reject the return of any products sold pursuant to this agreement. Specifically, Prinsco will not accept the return of products that are not in a saleable condition and are not part of the current product line. Products accepted for return by Prinsco are subject to a restocking charge equal to fifteen percent (15) of the sale price of the products. Applicable freight/shipping charges may apply.

9. **FORCE MAJEURE.** When either party's ability to manufacture or deliver or receive or consume Product or to otherwise perform under this Contract (other than Buyer's obligation or ability to make payment for Product delivered under this Contract) is impeded, restricted, or affected (A) by any cause such as, but not limited to, (i) fire, explosion, flood, storm, earthquake, tidal wave, war, military operation, national emergency, civil commotion, or other event of the type of the foregoing, (ii) any strike or other difference with workers or unions (without regard to the reasonableness of acceding to the demands of such workers or unions),

(iii) any governmental law, regulation, decree, order, or similar act, or (iv) and shortage in supplies of or impairment in the facilities of production, manufacture, transportation, or distribution of, either party attribute to (a) mechanical or other breakdown or failure, (b) the order, requisition, request, or recommendation of any governmental agency or acting governmental authority, or either party's compliance therewith, (c) governmental proration, regulation, or priority, or (d) the inability of Prinsco to obtain, on terms deemed by Prinsco to be commercially practicable, any feedstock or other raw material (including energy) or (B) by any cause beyond such party's control, whether similar or dissimilar to any aforementioned cause, then the party whose ability is so impeded, restricted, or affected is relieved of the obligation to perform hereunder, and that duty is permanently canceled rather than merely suspended. For the purpose of the application and interpretation of the provisions of this Paragraph 9, it is expressly deemed that all Product is to be produced at one or more facilities owned or operated by Prinsco. If Prinsco's ability to supply Buyer with Product from Prinsco's facilities is impeded, restricted, or affected by one or more of the aforementioned causes, then Prinsco shall not be obligated to purchase or obtain Product for Buyer on the open market or from other producers or suppliers of Product. However, in the event that Prinsco should, nevertheless, determine, in its sole discretion, to purchase or obtain Product on the open market or from other producers or suppliers of Product, then any such purchase or obtaining of Product shall constitute a waiver or estoppel of Prinsco's rights, or otherwise preclude Prinsco from asserting its rights, under this Contract not to purchase or obtain, or continue to purchase or obtain, Product for Buyer. Prinsco's obligation to sell product is subject to modification and reduction in accordance with any present or future allocation program of Prinsco or of any governmental authority.

Revised 03.21.2024